

Concord

August 1999



Blank Page

Table of Contents

Planning the Installation

Major Features.....	1-1
System Components.....	1-2
Planning Wires and Current Draw.....	1-4
Using the Planning Checklist.....	1-6
Planning Partitions.....	1-7
Global Settings.....	1-7
Partition-Specific Settings.....	1-7
Programming Partitions.....	1-7
System Planning Worksheets.....	1-8
System Wiring Notes.....	1-13

Installation

Installing the Panel (60-734).....	2-2
Running Wires to the Panel Location.....	2-3
Identifying the Main Components.....	2-4
Connecting the Panel to Earth Ground.....	2-5
Installing the Power Line Carrier (PLC) (60-755).....	2-5
Installing SnapCards (60-756, 60-757, 60-758).....	2-6
Combo SnapCard.....	2-7
Input SnapCard.....	2-8
Output SnapCard.....	2-9
Connecting Detection Devices to the Panel Zone Inputs.....	2-10
Connecting Two-Wire Smoke Detectors to the Panel.....	2-11
Connecting the 15-Watt Speaker (13-060).....	2-12
Connecting a Hardwire Interior Speaker.....	2-13
Connecting the Hardwire Exterior Siren (13-046).....	2-13
Connecting the Slim Line Hardwire Interior Siren (60-483-01).....	2-13
Connecting SuperBus Phone Interface/Voice Module (60-777).....	2-14
Connecting SuperBus Energy Saver Module (ESM) (60-620).....	2-15
Connecting SuperBus Hardwire Input Module (HIM) (60-584).....	2-16
Connecting SuperBus Hardwire Output Module (HOM) (60-585).....	2-17
Connecting SuperBus RF Receiver (60-764-95R).....	2-17
Setting Unit Number DIP Switches on Bus Devices.....	2-18
Connecting Alphanumeric and LED Touchpads (60-728 and 60-746).....	2-20
Connecting Phone Lines to the Panel.....	2-21
Connecting the AC Power Transformer (60-761).....	2-22
Powering Up the Panel.....	2-23

Peripheral Installation

Locating Wireless Sensors	3-2
Installing the Door/Window Sensor (60-362)	3-5
Installing the Slim Line Door/Window Sensor (60-499)	3-6
Installing the Micro Recessed Door/Window Sensor (60-741-95)	3-7
Connecting 2-Wire Smoke Detectors	3-8
Installing the 2100 (60-506-319.5) and 2300 (60-645-95) Smoke Sensors.....	3-9
Installing the IntelliSense Sound Sensor (60-582)	3-10
Installing the Rate of Rise Heat Sensor (60-460).....	3-13
Installing the PIR Wall Mount Motion Sensor (60-511).....	3-14
Installing the Shock Sensor (60-461)	3-15
Installing the Supervised Wireless Interior Siren (60-736-95)	3-15
Installing the X-10 Lamp Control Module (13-204)	3-16

Programming

Entering and Exiting Programming Mode	4-2
Entering Programming Mode	4-2
Exiting Programming Mode	4-2
Clearing Memory.....	4-3
Tour of the Concord Programming Menus	4-4
Navigating Through the Menus	4-5
Concord Programming Menus	4-6
Using Menu Shortcuts	4-11
Programming Shortcuts	4-11
Programming Defaults and Definitions	4-15
Learning Sensors.....	4-37
Sensor Group Characteristics Table	4-39
Tripping Learn Mode Wireless Sensors	4-41
Viewing Sensor Information	4-43
Verifying the Bus Device Unit Numbers	4-45
Changing the Bus Device Unit Number for an ATP (Alphanumeric Touchpad).....	4-46
Deleting a Bus Driver Unit Number.....	4-47
System Configuration Worksheets.....	4-48

Testing the System

Testing Sensors.....	5-2
Tripping Learn Mode Wireless Sensors	5-4
Correcting a Failed Sensor.....	5-6
Testing Telephone Communications.....	5-7
Testing Central Station/Pager Communication.....	5-8
Testing Outputs	5-9
Testing the Light Control	5-9
Testing the Energy Saver Module	5-10

Troubleshooting

Basic Troubleshooting	6-2
Power Troubles	6-2
Phone Troubles	6-4
Programming Troubles	6-5
Wireless Device Troubles.....	6-6
Hardwired Device Troubles.....	6-9
Line Carrier Troubles	6-10
Normal Operation Troubles.....	6-11

System Operation

Basic System Commands.....	7-2
Arming the System	7-4
Disarming the System.....	7-7
Bypassing Window or Door Sensors	7-8
Sending Panic Alarms	7-10
Checking System Status	7-13
Understanding Access Codes	7-14
The System Master Code:	7-14
Partition Master Codes	7-14
Regular User Codes	7-14
Adding or Changing an Access Code	7-14
Deleting a Regular User Access Code	7-15

End-User Training

What You Need to Know to Operate Your System.....	8-1
User Programming Menu	8-2
Arming and Disarming the System.....	8-4
Touchpad: Arming and Disarming the System	8-4
Telephone: Arming and Disarming the System	8-6
Keychain Touchpad: Arming and Disarming the System.....	8-8
Bypassing Window or Door Sensors	8-9
Touchpad: Bypass Window or Door Sensors.....	8-9
Telephone: Bypass Window or Door Sensors.....	8-10
Checking the System Status.....	8-11
Touchpad: Checking the System Status	8-11
Recent Alarm Check.....	8-12
End-User Training Exercise	8-13

CONCORD

Module 1-Planning the Installation

Introduction

This module teaches the installer how to plan the installation of the Concord system.

What's in This Module

Major Features	1-1
System Components	1-2
Planning Wires and Current Draw	1-4
Using the Planning Checklist	1-6
Planning Partitions.....	1-7
System Planning Worksheets.....	1-8
System Wiring Notes.....	1-13

Major Features

This section outlines the major features of the Concord system. You need to understand the system before planning the installation.

- 2 versions: hybrid and hardwire
- 2 partitions
- 1,500-foot range
- Attack resistant metal housing
- SAW radio receiver
- 60 user codes
- 100 event buffer
- Latchkey paging
- 16 programmable schedules
- Key-switch arming
- Siren driver
- One 2-wire smoke loop on board
- 12 VDC 1 Amp power 30 VA transformer
- 12 VDC 2 Amp power 50 VA transformer
- Supervised Wireless Interior Siren (SWIS) Compatible (Requires PLC card)
- 16 SuperBus Modules
- SIA II and contact ID reporting formats (no ITI format)
- Snap Cards allow expansion of features
 - 6-zone Input with two 2-wire smoke loops
 - 4 Form-C relay output
 - Combination input/output (3 input 2 output, two-wire smoke loop)
- 2-Way communication with central station operators using optional Interrogator 200 Audio Verification Module
- Hardwired touchpads display text descriptions of alarms and sensor conditions
- Energy Saver
- Optional Phone Interface Voice/Module to control the system when your on or off the premises and for status voice
- PC downloader programmable ITI ToolBox Downloader

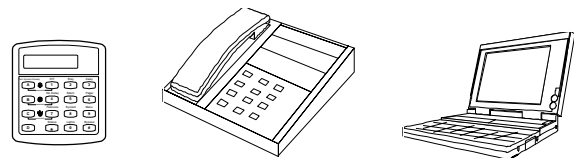

Student Notes

System Components

This task familiarizes you with the basic components of the Concord system.

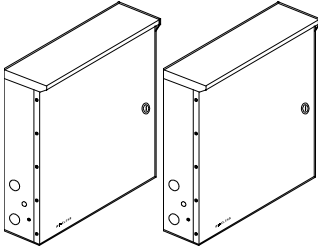

- Panels Versions
 - Concord Hardwire
 - Concord RF 16
 - Concord RF 32

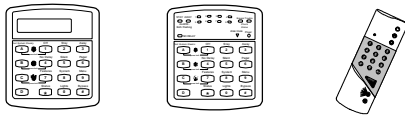

- Touchpads (Maximum of 4)
 - Concord uses 4 hardwire touchpads.
 - Hi-Tech Handheld Touchpad
 - 2- and 4-button keychain touchpads



- SuperBus RF Receivers
 - 16 zone wireless receiver
 - 32 zone wireless receiver
 - 76 zone wireless receiver
- Optional Power Line Carrier (PLC) Card
 - Allows use of Supervised Wireless Interior Siren and X-10 devices

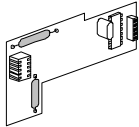

- Optional Phone Line Supervision Card
- Optional Phone Interface/Voice Module
 - Allows operation from a touch-tone phone and gives system a 220+ word vocabulary

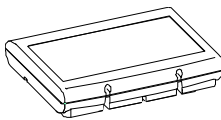

- Optional Snap Cards
- 8Z Input Card
 - Adds 6 hardwire zones and two 2-wire smoke loops

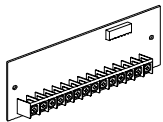

- 4Z Output Card
 - Adds 4 Form-C relay outputs

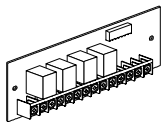

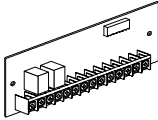

- I/O Combo Card
 - Adds one 2-wire smoke loop
 - Three hardwire zones
 - Two hardwire outputs

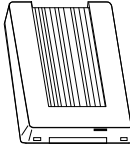

- SuperBus Hardwire Input Module
 - Adds 8 hardwire inputs

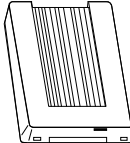

- SuperBus Hardwire Output Module
 - Adds 4 Form-C relay outputs



- Supervised Wireless Interior Siren (SWIS)



- Interrogator 200 Audio Verification Module
 - Provides voice communication with the Central Station
- Energy Saver Module
 - Allows the Concord system to control a thermostat

Student Notes

Planning Wires and Current Draw

This task helps you determine what wire you need and minimum current draw for each device.

TABLE 1-1. Wire Length and Maximum Current Draw for Devices.

Device	Maximum Wire Length to Panel	Maximum mA Draw
SuperBus 2x16 LCD Alphanumeric Touchpad	22 ga.—300 ft. 18 ga.—750 ft.	90 mA
SuperBus 8Z LED Touchpad	22 ga.—300 ft. 18 ga.—700 ft.	65 mA
SuperBus 2x20 LCD Alphanumeric Touchpad	22 ga.—250 ft. 18 ga.—600 ft.	120 mA
SuperBus 2x20 VFD Alphanumeric Touchpad	22 ga.—250 ft. 18 ga.—600 ft.	120 mA
SuperBus RF Receiver	22 ga.—1,100 ft. 18 ga.—2,800 ft.	30 mA
SuperBus Phone Interface/ Voice Module	22 ga.—40 ft. 18 ga.—120 ft.	600 mA
Power Line Carrier Card	N/A	110 mA
4 Input/2 Output SnapCard	N/A	185 mA
8Z Hardwire Zone Expander SnapCard	N/A	230 mA
4 Output SnapCard	N/A	130 mA
SuperBus Hardwire Input Module	22 ga.—1,800 ft. 18 ga.—4,500 ft.	18 mA
SuperBus Hardwire Output Module	22 ga.—350 ft. 18 ga.—900 ft.	91 mA
SuperBus Energy Saver Module	22 ga.—1,600 ft. 18 ga.—4,000 ft.	20 mA
Interrogator 200	22 ga.—3,200 ft. 18 ga.—4,500 ft.	10 mA
Interrogator AVM	22 ga.—110 ft. 18 ga.—260 ft.	300 mA

TABLE 1-2. Total Allowed Wire Length for System.

Wire Type	Total System Wire for Systems <i>with</i> LED Touchpads	Total System Wire for Systems <i>without</i> LED Touchpads
22-gauge, unshielded	2,000 ft.	4,500 ft.
22-gauge, shielded	1,300 ft.	3,000 ft.
18-gauge, unshielded	1,600 ft.	3,500 ft.
18-gauge, shielded	900 ft.	2,200 ft.

Refer to Table 1-3 for the minimum current draw of each device when the panel is operating only from the backup battery. For 24-hour backup, the total current draw of all connected devices is limited to 100 mA continuous using a 4.0 AH battery, or 200 mA continuous using a 7.0 AH battery.

TABLE 1-3. Current Draw Minimums for Devices.

Device	Minimum mA Draw
SuperBus 2x16 LCD Alphanumeric Touchpad	15 mA
SuperBus 8Z LED Touchpad	15 mA
SuperBus 2x20 LCD Alphanumeric Touchpad	20 mA
SuperBus 2x20 VFD Alphanumeric Touchpad	20 mA
SuperBus RF Receiver	27 mA
SuperBus Phone Interface/Voice Module	25 mA
Power Line Carrier Card	N/A
4 Input/2 Output SnapCard	20 mA
8Z Hardwire Zone Expander SnapCard	38 mA
4 Output SnapCard	1 mA
SuperBus Hardwire Input Module	18 mA
SuperBus Hardwire Output Module	11 mA
SuperBus Energy Saver Module	20 mA
Interrogator 200	10 mA
Interrogator AVM	45 mA

TABLE 1-4. Wiring Requirements for Devices.

Device	Wire Requirements
AC Power Transformer	2-conductor, 18-gauge, 25 feet maximum
Earth Ground	Single conductor, 16-gauge solid, 25 feet maximum
Telephone (RJ-31X)	4-conductor
Detection Devices	2- or 4-conductor, 18- to 22-gauge, 50 ohms maximum loop resistance including device
Sirens/Speakers	2-conductor, 18- 22-gauge
SuperBus Devices	4-conductor, 22- or 18-gauge
Interrogator 200 AVM Power and Microphone	4-conductor, 22-gauge, shielded

Using the Planning Checklist

Use the following System Planning Checklist for a quick, error-free installation.

- How will the system be used? (fire warning, intrusion alarm, partitions, etc.)

- Will there be hardwired components?

- Which wireless components will be used?

- Where will the control panel, touchpad, and sensors be located?

- Plan panel option programming:
 - Which panel configuration options will be used?

- Who will train the users?

- How and when will the users be trained?

- Do you have all the components you need for the job?

Student Notes

Planning Partitions

This task illustrates planning a system that uses partitions. Partitioning allows a system to be used like it's more than one system.

Concord has two partitions. That means that one Concord system could be set up to provide security for two businesses. The users would not know that they were using the same system.

Global Settings

System Settings that affect both partitions:

- The time and date
- The System Master code
- The phone number of the central monitoring station
- The downloader phone number
- The Dialer Delay feature

Partition-Specific Settings

System Settings that affect either partition:

- The Partition Maser code (1 per partition)
- The user access codes (60 total)
- Pager phone numbers
- Light control (9 total)
- The Latchkey feature
- The Notify by Exception feature
- The Downloading option
- The Silent Arming option
- Touchpad brightness settings
- Speaker volume settings
- The Energy Saver Module (ESM) feature and its high and low set points

Programming Partitions

Only one partition can be programmed at a time.

While one partition is being programmed, the other partition cannot be programmed. Some partition-specific settings share resources, such as access codes and time schedules. This means that if Partition 1 uses user numbers 1 through 20, Partition 2 cannot use those numbers.

CONCORD
Planning the Installation

System Planning Worksheets

Fill in customer information about this installation:

Customer _____

Address _____

City _____ State/Zip _____

Country _____ Phone _____

TABLE 1-5. Wireless Sensors.

Part No.	Description	Quantity
60-362	Learn Mode Door/Window Sensor	
60-409	Learn Mode Recessed Door/Window Sensor	
60-499	Learn Mode Slim Line Door/Window Sensor	
60-461*	Learn Mode Shock Sensor	
60-459 *	Learn Mode Sound Sensor (ITI)	
60-462 *	Learn Mode Glass Guard Sensor	
60-506	Learn Mode System Smoke Sensor	
60-460	Rate-of-Rise Heat Sensor	
60-589 *	Manual Fire Pull Sensor	
60-504 *	Learn Mode Freeze Sensor	
60-452	Learn Mode Pendant Panic Sensor	
60-458	Single Button Panic Sensor	
60-457	Dual Button Panic Sensor	
60-578	Water-Resistant Panic Sensor	
60-348	Handheld Wireless Touchpad	
60-453	Wall-Mount Wireless Touchpad	
60-511	Learn Mode DS924i PIR Motion Sensor	
60-592	DS926 PIR Ceiling Mount Motion	
60-582	Learn Mode Sound Sensor (IntelliSense)	
60-645-95	Wireless Smoke Sensor (System Sensor 2300RFIT)	

* Not UL listed; not intended for use in UL listed systems.

TABLE 1-6. Hardwire Devices.

Part No.	Description	Qty.	mA	Sub
Hardwire Sensors/Detectors				
13-068 *	Magnetic Contact 3/8" press fit		N/A	
13-070 *	Magnetic Contact Surface Mount		N/A	
13-360	ESL 449AT Smoke/Heat Detector		15 mA	
13-391	Power Supervision Module		20 mA	
79-004 *	Fire Pull Station		N/A	
13-028 *	PIR Motion Detector		10 mA	
Hardwire Sirens				
60-252	Hardwire Interior Speaker and Piezo		5 mA	
60-278	Hardwire Interior Siren and Piezo		75 mA	
60-483	Slim Line Hardwire Interior Siren and Piezo		120 mA	
13-046	Hardwire Exterior Siren		145 mA	
Miscellaneous Components				
60-584	Superbus Hardwire Input Module (HIM)		15 mA	
60-586	Superbus Alphanumeric Touchpad		100 mA	
60-620	Superbus Energy Saver Module (ESM)		10 mA	
60-661	Superbus 2-Line, LCD Alphanumeric TP		115 mA	
60-662	Superbus 2-Line, VFD Alphanumeric TP		120 mA	
60-677 *	Audio Verification Module (AVM)		10 mA	

* Total power consumption not to exceed: 1,000 mA

TABLE 1-7. Recommended Superbus Device Unit Number (Addresses)

Superbus Device	Factory Default	Actual Setting
First Alphanumeric Touchpad	1	
Second Alpha. Touchpad	1	
Third Alpha. Touchpad	1	
Fourth Alpha. Touchpad	1	
Hardwire Input Module (HIM)	0	
Energy Saver Module (ESM)	0	

TABLE 1-8. Sensor Groups and Locations.

No.	Group	Type and Location	No.	Group	Type and Location
01			39		
02			40		
03			41		
04			42		
05			43		
06			44		
07			45		
08			46		
09			47		
10			48		
11			49		
12			50		
13			51		
14			52		
15			53		
16			54		
17			55		
18			56		
19			57		
20			58		
21			59		
22			60		
23			61		
24			62		
25			63		
26			64		
27			65		
28			66		
29			67		
30			68		
31			69		
32			70		
33			71		
34			72		
35			73		
36			74		
37			75		
38			76		

CONCORD
 Planning the Installation

TABLE 1-9. Sensor Group Characteristics .

No.	Name	Application	Alarm	Delay	Restoral	Supervisory	CS Report	Chime	Active Levels
00	Fixed Panic	24-hour audible fixed emergency buttons.	Police	Instant		✓	✓		1, 2, 3
01	Portable Panic	24-hour audible portable emergency buttons.	Police	Instant			✓		1, 2, 3
02	Fixed Panic	24-hour silent fixed emergency buttons.	Silent	Instant		✓	✓		1, 2, 3
03	Portable Panic	24-hour silent portable emergency buttons.	Silent	Instant			✓		1, 2, 3
04	Fixed Auxiliary	24-hour auxiliary sensor, such as Pendant Panic or holdup button.	Auxiliary	Instant		✓	✓		1, 2, 3
05	Fixed Auxiliary	24-hour auxiliary emergency button. Siren shutoff confirms CS report.	Auxiliary	Instant		✓	✓		1, 2, 3
06	Portable Auxiliary	24-hour portable auxiliary alert button.	Auxiliary	Instant			✓		1, 2, 3
07	Portable Auxiliary	24-hour portable auxiliary button. Siren shutoff confirms CS report.	Auxiliary	Instant			✓		1, 2, 3
08	Special Intrusion	Special belongings, such as gun cabinets and wall safes.	Police	Instant	✓	✓	✓		1, 2, 3
09	Special Intrusion	Special belongings, such as gun cabinets and wall safes.	Police	Standard	✓	✓	✓		1, 2, 3
10	Entry/Exit Delay	Entry and exit doors that require a standard delay time.	Police	Standard	✓	✓	✓	✓	2, 3
11	Entry/Exit Delay	Garage doors and entrances that require an extended delay time. *	Police	Extended	✓	✓	✓	✓	2, 3
12	Entry/Exit Delay	Driveway gates and entrances that require a twice extended delay time. *	Police	Twice Extended	✓	✓	✓	✓	2, 3
13	Instant Perimeter	Exterior doors and windows.	Police	Instant	✓	✓	✓	✓	2, 3
14	Instant Interior	Interior doors.	Police	Follower	✓	✓	✓		2, 3
15	Instant Interior	Interior PIR motion sensors. *	Police	Follower		✓	✓		2, 3
16	Instant Interior	Interior doors.	Police	Follower	✓	✓	✓		3
17	Instant Interior	PIR motion sensors. *	Police	Follower		✓	✓		3
18	Instant Interior	PIR motion sensors subject to false alarms. * †	Police	Follower		✓	✓		3
19	Delayed Interior	Interior doors that initiate a delay before going into alarm. *	Police	Standard	✓	✓	✓		3
20	Delayed Interior	PIR motion sensors that initiate a delay before going into alarm. *	Police	Standard		✓	✓		3

TABLE 1-9. Sensor Group Characteristics (Continued).

No.	Name	Application	Alarm	Delay	Restoral	Supervisory	CS Report	Chime	Active Levels
21	Local Instant Interior	24-hour local alarm zone protecting anything that opens and closes.	Police	Instant	✓	✓			1, 2, 3
22	Local Delayed Interior	Same as group 21, plus activation initiates a delay before going into alarm.	Police	Standard	✓	✓			1, 2, 3
23	Local Instant Auxiliary	24-hour local alarm zone protecting anything that opens and closes. †	Auxiliary	Instant	✓	✓			1, 2, 3
24	Local Instant Auxiliary	24-hour local alarm zone protecting anything that opens and closes. Sirens shut off at restoral. *	Auxiliary	Instant	✓	✓			1, 2, 3
25	Local Special Chime	Notify the user when a door is opened. Sounds emit from a local annunciator. *	Special Chime	Instant		✓			1, 2, 3
26	Fire	24-hour fire, rate-of-rise heat, and smoke sensors. §	Fire	Instant	✓	✓	✓		1, 2, 3
27	Output Module	Hardwire Output Module (HOM) lamp control or other customer feature. †	Silent	Instant	✓	✓			1, 2, 3
28	Output Module	HOM, PIR motion sensor, sound sensor, or pressure mat. †	Silent	Instant		✓			1, 2, 3
29	Auxiliary	Freeze sensor.	Auxiliary	Instant	✓		✓		1, 2, 3
32	Output Module	HOM, PIR motion sensor, sound sensor, or pressure mat. †	Silent	Instant					1, 2, 3
33	Siren	Wireless Siren Supervision	Silent	Instant		✓	✓		1, 2, 3
34	Gas	Carbon monoxide (CO) Gas Detector	Auxiliary	Instant	✓	✓	✓		

Note: Check marks (✓) represent characteristics present in a group.

* This group is not certified as a primary protection circuit for UL-listed systems and is for supplementary use only.

† Sounds instant police siren if two or more sensors are tripped within 4 minutes. Otherwise sensors are followers to delayed sensors. If Alarm Verification is on, group 18 functions like group 17.

‡ This group has not been investigated by UL.

§ This group is required for UL-listed residential fire alarm applications.

ALL PANEL TERMINAL CONNECTIONS ARE CLASS II POWER LIMITED

SYSTEM WIRING DIAGRAM
(See notes on other side.)

85731198.DSF

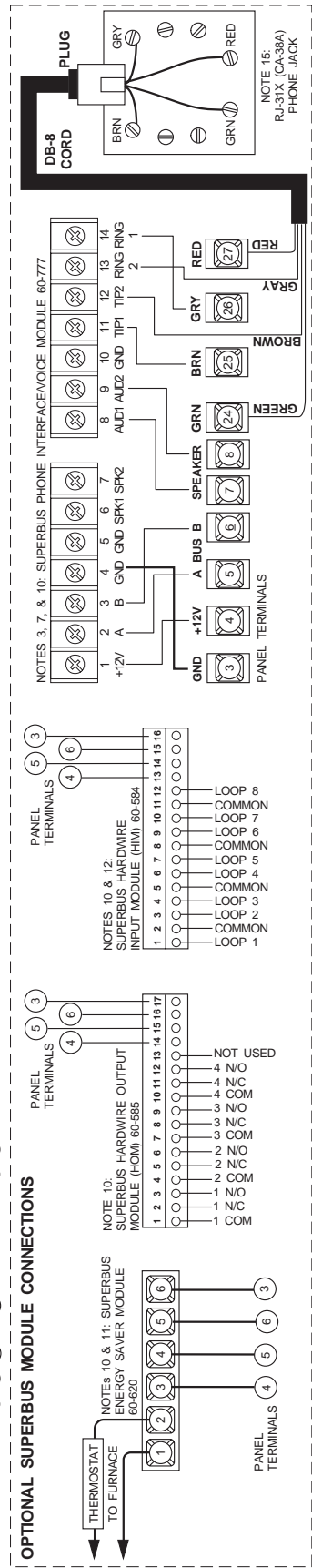
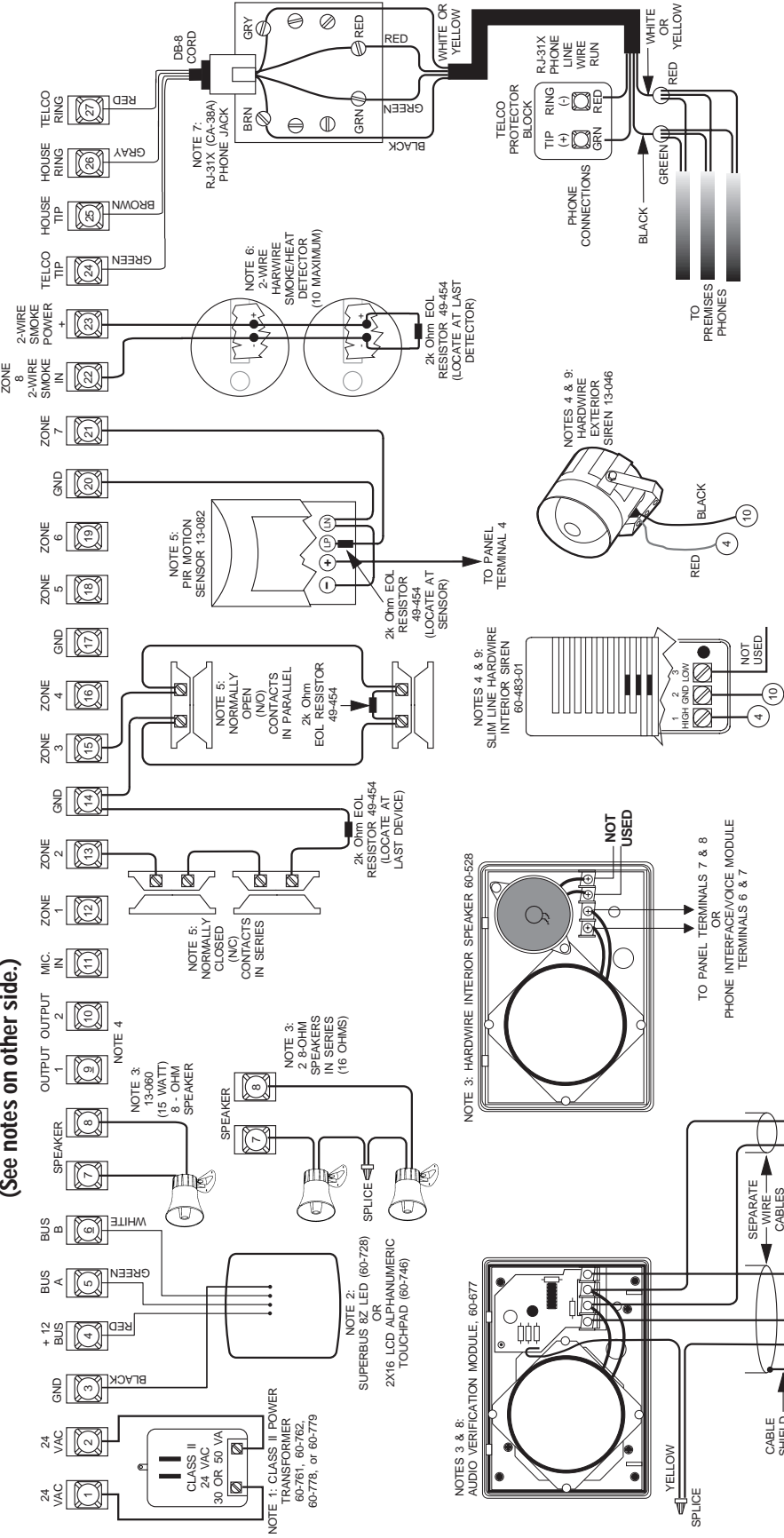

System Wiring Notes

Note 1

Class II power transformer must be plugged into an unswitched AC power receptacle. Do not short the transformer terminals together. The transformer contains an internal fuse that permanently disables the output if the terminals are shorted.

Note 2

An alphanumeric touchpad is required for on-site programming. If the installation includes more than one touchpad, connect just one touchpad and use it to program system settings. When connecting additional touchpads, each one must be set with a unique device address. Refer to the touchpad or panel installation instructions.

Note 3

Speaker terminals 7 and 8 activate only for alarms in partition 1. Use speakers with an 8-ohm or higher impedance. When connecting two or more 8-ohm speakers, they must be wired in series as shown in the wiring diagram. Wiring two or more 8-ohm speakers in parallel can permanently damage the panel.

Note 4

Onboard outputs 1 and 2 are open-collector type. Output 1 defaults to configuration number 01400. Output 2 defaults to configuration number 00410. Refer to panel installation instructions for all possible settings.

Note 5

Zone (loop) wiring is an example that applies to all zones (except when zone 8 is configured for 2-wire smoke detectors). Install EOL resistors across all unused zone (loop) inputs.

Note 6

For UL listed installations, wire multiple supervised hardwire smoke detectors (10 maximum) only as shown. Maximum 10 μ A current draw per detector. Maximum 80 mA current draw in alarm. Maximum 100 mA current draw in non-alarm state.

Note 7

Some telephones are polarity-sensitive. Green and red wires may need to be reversed.

Note 8

A maximum of two Audio Verification Modules are allowed. Wire multiple speakers in series, and power and microphone wires in parallel. Use shielded cable where shown in diagram to prevent cross-talk between the speaker and microphone. Audio Verification Modules may not be used in UL listed installations.

Note 9

Connect multiple piezo sirens in parallel. Status beeps do not sound from piezo sirens connected to outputs. Slim line hardwire interior siren status volume switch settings have no effect.

Note 10

All SuperBus devices must be set with a different device address before applying power. Devices with the same device address setting will not work correctly. For installations with just one touchpad and module, the default settings can be used.

Note 11

Refer to the Energy Saver Module installations instructions for thermostat wiring details.

Note 12

Wire hardwire input module zone (loop) inputs as shown for the panel, except use 4.7k-ohm EOL resistors. Install EOL resistors across all unused zone (loop) inputs.

CONCORD
Planning the Installation

Module 2-Installation

Introduction

This module teaches you how to install the Concord Security System.

What's in This Module

Installing the Panel (60-734).....	2-2
Connecting the Panel to Earth Ground.....	2-5
Installing the Power Line Carrier (PLC) (60-755).....	2-5
Installing SnapCards (60-756, 60-757, 60-758)	2-6
Connecting Detection Devices to the Panel Zone Inputs.....	2-10
Connecting Two-Wire Smoke Detectors to the Panel	2-11

Installing the Panel (60-734)

This task illustrates finding the best location and mounting the panel.

CAUTION

Do not apply power to the panel until all module/card installation and panel wiring is completed. Determine the panel location.

- Use a central location.
- Avoid excessive metal if the SuperBus RF receiver is used (HVAC ducts, foil wallpaper, gas/water pipes, and electrical wiring)
- Mount the panel at a comfortable working height (about 45 to 55 inches from the floor).
- Allow a minimum of 9 inches above the panel for the antennas, if the SuperBus RF receiver is used.
- Allow space to the right or left of the panel for wiring, phone jack, and optional module mounting.
- Allow at least 24 inches in front of the panel for access.

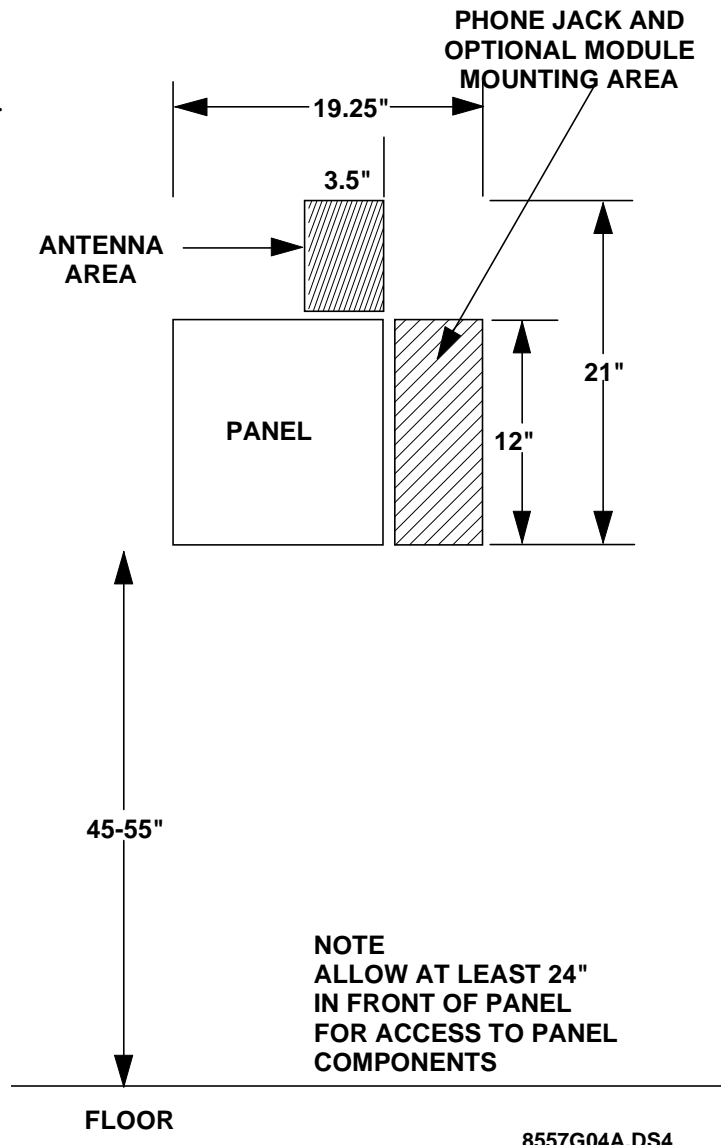

FIGURE 2-1. Determining the Panel Location.

Running Wires to the Panel Location

After determining the panel location, run all the necessary wires to the location using the Table 2-1 below.

CAUTION

Make sure you are free of static electricity whenever you work on the panel with the cover open. Discharge static by first touching the metal panel chassis, then stay in contact with the chassis when touching the circuit board. Using an approved grounding strap is recommended.

TABLE 2-1. Control Panel Wiring Requirements.

Device	Wire Requirements
AC Power Transformer	2-conductor, 18-gauge, stranded, 25 feet maximum
Earth Ground	Single 14-gauge, stranded or solid, 25 feet maximum
Telephone (RJ-31X)	4-conductor, 22- to 24-gauge, solid or stranded
Detection Devices	2- or 4-conductor, 18- to 22-gauge, stranded, 50 ohms maximum loop resistance including device
Sirens, Piezos, and Speakers	2- or 4-conductor, 18-gauge, stranded, 500 feet maximum
SuperBus Devices (alphanumeric touchpad, HIM, and ESM)	4-conductor, 22-gauge, maximum 500 feet
LED Touchpad	4-conductor, 22-gauge, 300 feet maximum
SuperBus RF Receiver	4-conductor, 22-gauge, 1,100 feet maximum
Phone Interface and Voice Module	4-conductor, 18- to 22-gauge, 50 feet maximum
Interrogator 200 AVM Microphone	2-conductor, 22-gauge, stranded, shielded*, 500 feet maximum

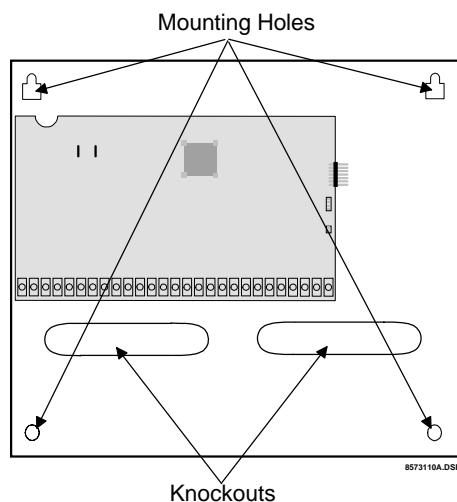

FIGURE 2-2. Mounting the Panel.

1. Open the panel cover.
2. Remove the necessary wiring knockouts. Be careful not to damage the circuit board.
3. Feed all wires through the wiring knockouts.
4. Place the panel in position against the wall (or studs).
5. Level the enclosure and mark the locations of the two mounting holes and two keyhole mounting holes.
6. Use the right anchors and screws. Partially insert screws into the two anchors at the top keyhole locations, and then hang the panel chassis on the two screws.
7. Level the enclosure. Insert the two lower screws, and then tighten all four mounting screws.

NOTE

Remember to leave room for the antennas, which extend 9 inches above the top of the enclosure.

Identifying the Main Components

This task illustrates the location of the panel's main components.

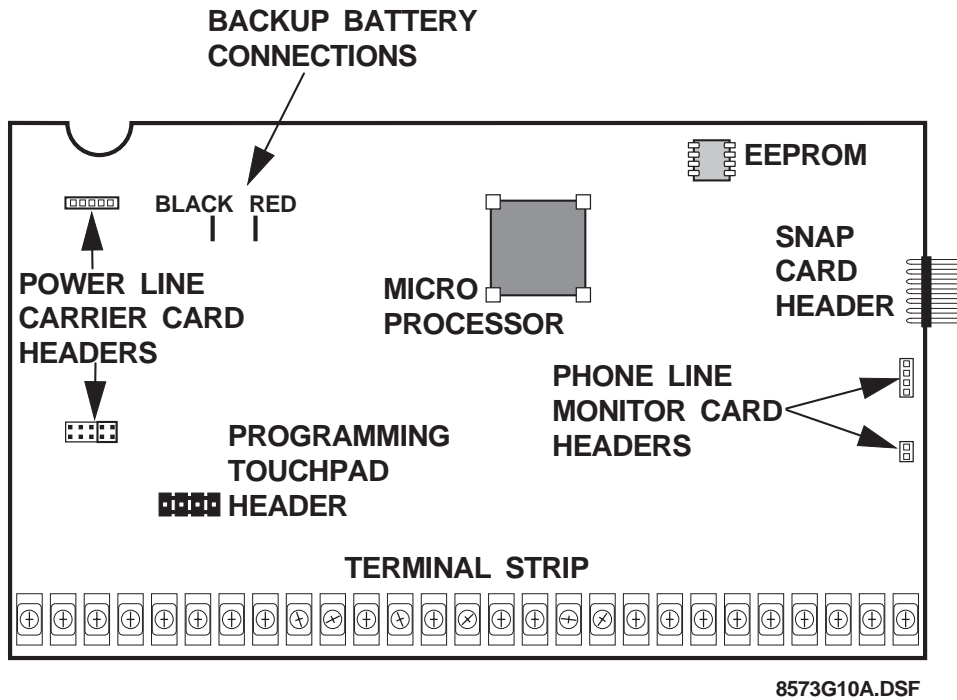

FIGURE 2-3. Concord Panel Main Components.

Student Notes

Connecting the Panel to Earth Ground

This task illustrates connecting the panel to earth ground to protect from lightning strikes and transients.

CAUTION

Do not apply power to the panel until all module/card installation and panel wiring is completed.

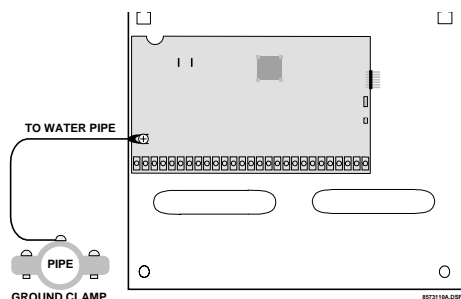

1. Using a spade lug, connect a 16-gauge, solid copper wire to the lower-left circuit board screw.
2. Connect the other end of the wire to an earth ground, for example: an earth grounded cold-water pipe clamp.

FIGURE 2-4. Grounding the Panel.

Installing the Power Line Carrier (PLC) (60-755)

This task illustrates installing the Power Line Carrier (PLC) card. The PLC card lets you add Supervised Wireless Sirens for alarm and status sounds and X-10 lamp modules for light control.

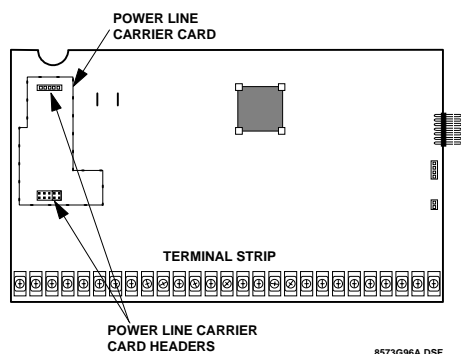

1. Install the card on the header pins shown in Figure 2-5.
2. No wiring or *programming* is necessary.

FIGURE 2-5. Header Pin Locations.

NOTE

The lower header has two jumpers installed from the factory that must be removed before installing the Power Line Carrier Card. Leave these jumpers in place if you are not installing a Power Line Carrier Card.

Installing SnapCards (60-756, 60-757, 60-758)

This task illustrates installing Snap Cards.

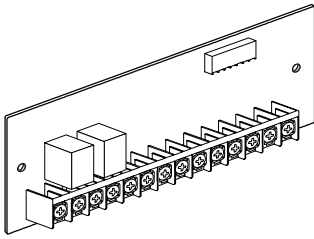
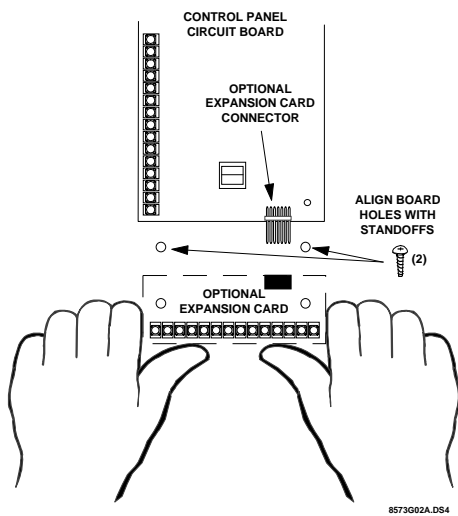

FIGURE 2-6. Combo Snap Card.



1. Disconnect the panel power and the backup battery.

2. Install the SnapCard onto the panel's SnapCard Header.

3. Secure the card with the two screws provided with the card.

4. Wire the input devices to the card. Refer to Figures 2-7 through 2-9 Tables 2-2 through 2-4.

Use terminals 11 and 12 for the two-wire 12V smoke detector loop. You can connect up to 20 two-wire smoke detectors on this loop.

5. Use end-of-line (EOL) resistors as shown on any hardwire loops.

6. Reconnect the backup battery and panel AC power.

Combo SnapCard

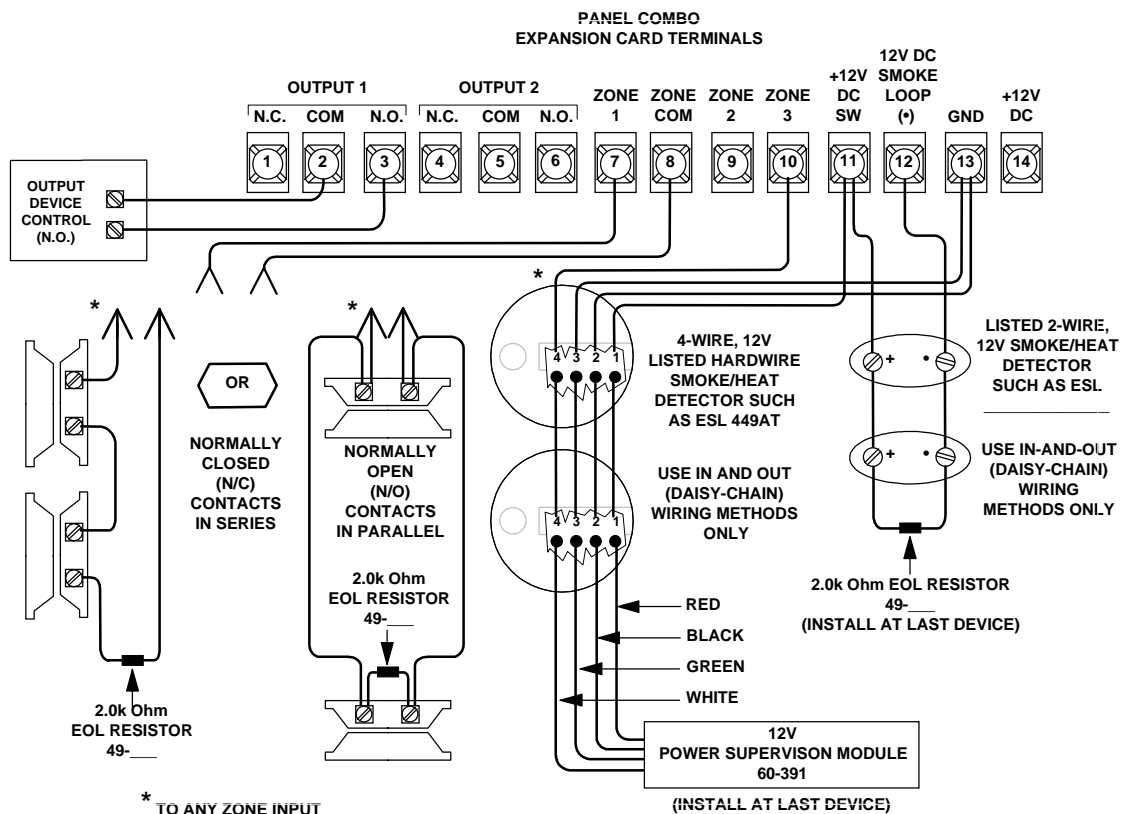

FIGURE 2-7. Combo SnapCard Wiring Diagram.

8587G01A.DS4

TABLE 2-2. Wiring Terminal Descriptions -Combo SnapCard.

Terminal Number	Description	Use
1	Relay 1 N/C	Normally closed (N/C) (opens on activation) output 1 dry relay contact connection.
2	Relay 1 COM	Common (C) side of output 1 dry relay N/C and N/O contacts (terminals 1 and 3). 5 AMP at 30 VDC maximum.
3	Relay 1 N/O	Normally open (N/O) (closes on activation) output 1 dry relay contact connection.
4	Relay 2 N/C	Normally closed (N/C) (opens on activation) output 2 dry relay contact connection.
5	Relay2 COM	Common (C) side of output 2 dry relay N/C and N/O contacts (terminals 2 and 6). 5 amp at 30 VDC maximum.
6	Relay 2 N/O	Normally open (N/O) (closes on activation) output 2 dry relay contact connection.
7	ZN1	Hardwire Input zone 1
8	ZCOM	Common for hardwire input zones 1, 2, and 3
9	ZN2	Hardwire Input zone 2
10	ZN3	Hardwire Input zone 3
11	SMK+	Smoke sensor power supply. Switched 12 VDC at 100 mA maximum. Positive (+) side of 2-wire, 12 VDC smoke loop.
12	SMK-	Negative (-) side of 2-wire, 12 VDC smoke loop.
13	GND	Common ground for 4-wire smoke sensors and rate-of-rise heat sensors
14	+12VDC	Auxiliary DC power supply. 12 VDC at 500 mA maximum.

Input SnapCard

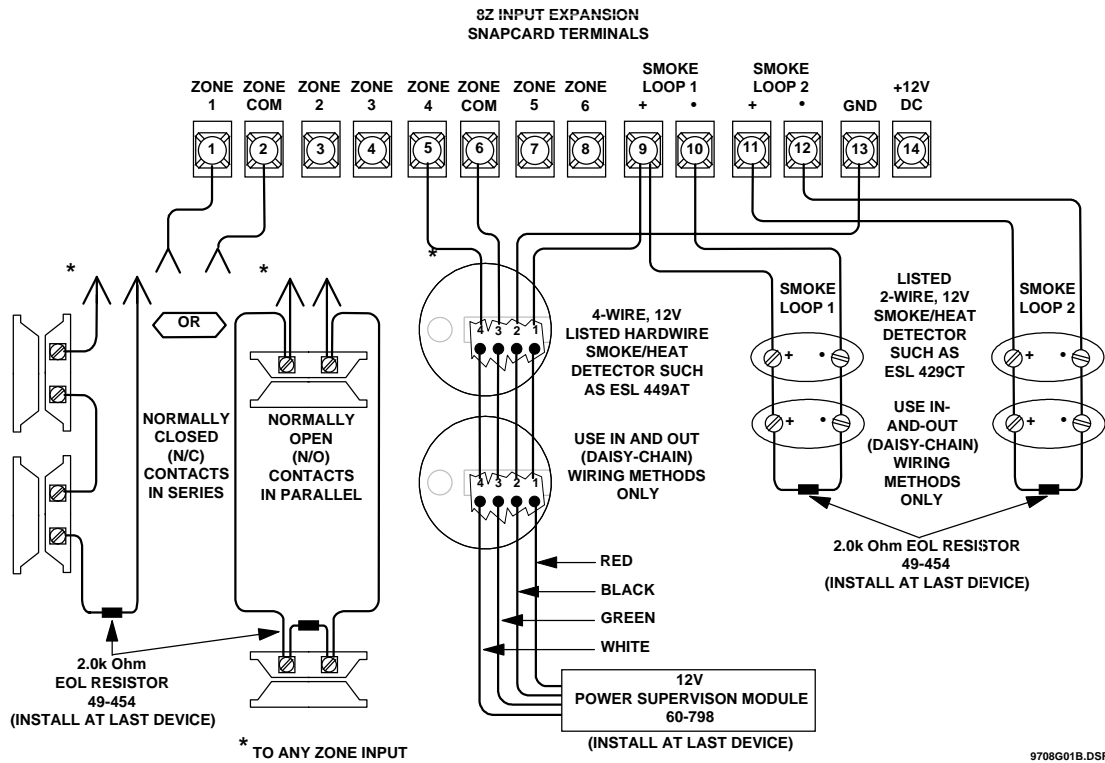

FIGURE 2-8. Input SnapCard Wiring Diagram.

TABLE 2-3. Wiring Terminal Descriptions - Input SnapCard.

Terminal Number	Description	Use
1	Zone 1	Hardwire input zone 1
2	Zone COM	Common for zones 1, 2, and 3
3	Zone 2	Hardwire input zone 2
4	Zone 3	Hardwire input zone 3
5	Zone 4	Hardwire input zone 4
6	Zone COM	Common for zones 4, 5, and 6
7	Zone 5	Hardwire input zone 5
8	Zone 6	Hardwire input zone 6
9	12V Smoke Loop 1 (Pos)	Positive side of 2-wire 12V smoke loop1. Connect up to 20 12V class B smoke detectors between terminals 9 and 10. (Terminal also supplies +12 VDC switched power to 4-wire smoke detectors).
10	12V Smoke Loop (Neg)	Negative side of 2-wire 12V smoke loop1
11	12 Smoke Loop 2 (Pos)	Positive side of 2-wire 12V smoke loop 2. Connect up to 20 12V class B smoke detectors between terminals 11 and 12. (Terminal also supplies +12 VDC switched power to 4-wire smoke detectors).
12	12 Smoke Loop 2 (Neg)	Negative side of 2-wire 12V smoke loop 2
13	GND	Auxiliary power supply ground return
14	+12VDC OUT	Auxiliary regulated DC power supply. 12 VDC at 0.5 amp maximum.

Output SnapCard

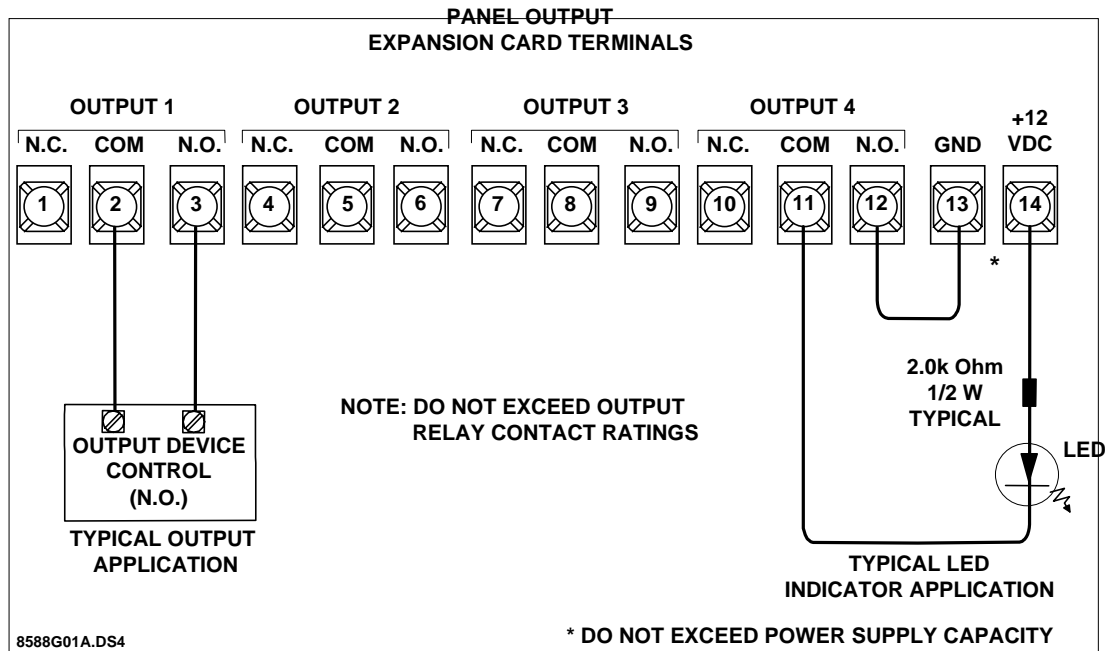

FIGURE 2-9. Output SnapCard Wiring Diagram.

TABLE 2-4. Wiring Terminal Descriptions - Output SnapCard.

Terminal Number	Description	Use
1	1 N/O	Normally open (N/O) (closes on activation) output 1 dry relay contact connection.
2	1 COM	Common (C) side of output 1 dry relay N/C and N/O contacts (terminals 1 and 3). 5 amp at 30 VDC maximum.
3	1 N/C	Normally closed (N/C) (opens on activation) output 1 dry relay contact connection.
4	2 N/O	Normally open (N/O) (closes on activation) output 2 dry relay contact connection.
5	2 COM	Common (C) side of output 2 dry relay N/C and N/O contacts (terminals 4 and 6). 5 amp at 30 VDC maximum.
6	2 N/C	Normally closed (N/C) (opens on activation) output 2 dry relay contact connection.
7	3 N/O	Normally open (N/O) (closes on activation) output 3 dry relay contact connection.
8	3 COM	Common (C) side of output 3 dry relay N/C and N/O contacts (terminals 7 and 9). 5 amp at 30 VDC maximum.
9	3 N/C	Normally closed (N/C) (opens on activation) output 3 dry relay contact connection.
10	4 N/O	Normally open (N/O) (closes on activation) output 4 dry relay contact connection.
11	4 COM	Common (C) side of output 4 dry relay N/C and N/O contacts (terminals 10 and 12). 5 amp at 30 VDC maximum.
12	4 N/C	Normally closed (N/C) (opens on activation) output 4 dry relay contact connection.
13	GND	Common ground return connection for 12 VDC supply output.
14	+12VDC	Auxiliary output regulated DC power supply. 12 VDC at 0.5 amp maximum.

Connecting Detection Devices to the Panel Zone Inputs

This task illustrates connecting hardwire devices to the panel.

If you are installing two-wire smoke detectors, you must configure the panel to recognize them. They must be connected to zone 8. See *Programming the System for Two-Wire Smoke Detectors in Module 4 – Programming* for step-by-step programming instructions.

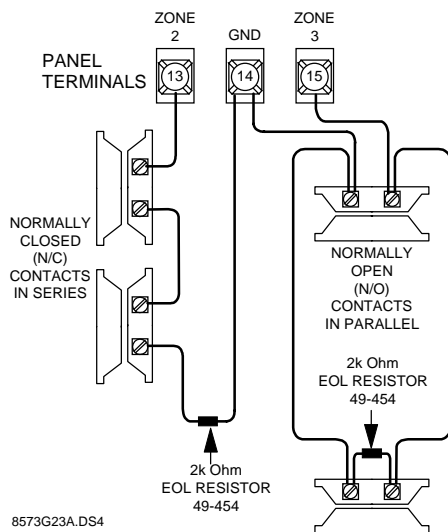

FIGURE 2-10. N/C and N/O Intrusion Detection Circuits.

Wire all zone inputs using a 2k-ohm end-of-line resistor to provide supervision for the zone.

Wire the end-of-line resistor at the last device on the circuit and accept either normally open (N/O) or normally closed (N/C) detection devices.

Refer to typical wiring for N/C and N/O intrusion detection circuits.

1. Using 2-conductor, 22-gauge or larger wire, connect your hardwire loops to the panel.
2. Verify that end-of-line resistors are installed properly (normally open sensors in parallel, normally closed sensor in series).

Connecting Two-Wire Smoke Detectors to the Panel

This task illustrates connecting two-wire smoke detectors to the panel.

You can connect up to ten 2-wire smoke devices to the panel.

NOTE

If you are installing two-wire smoke detectors, you must configure the panel to recognize them. They must be connected to zone 8. See *Programming the System for Two-Wire Smoke Detectors* in *Module 4 – Programming* for step-by-step programming instructions.

NOTE

When zone input 8 is set up for 2-wire smoke detectors, the maximum loop current allowed is 100 mA (in alarm)

Zone input 8 can be set up in program mode, to accept 12 VDC, 2-wire smoke detectors by the following manufactures:

- System Sensor models 2100, 2100T, 2400, and 2400T
- Sentrol models 429C, 429CT, 521B, 521BXT

1. Using 2-conductor, 22-gauge or larger wire, connect smoke detectors to the panel.

2. Verify that end-of-line resistors are installed properly (normally open sensors in parallel, normally closed sensor in series).

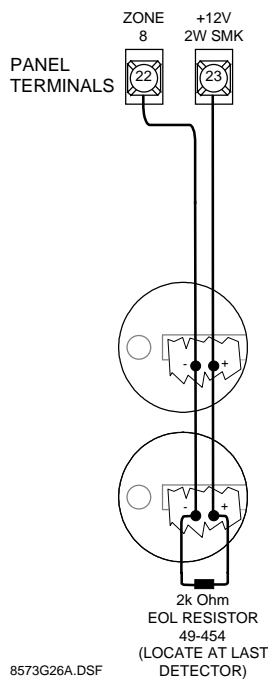

FIGURE 2-11. Connecting 2-wire Smoke Detectors to the Panel.

Connecting the 15-Watt Speaker (13-060)

This task illustrates connecting the 15-watt speaker to the Concord panel.

The panel provides one siren driver output for intrusion (warble) and fire (temporal 3) alarm sounds. This output trips only for partition one alarms.

The output accepts a minimum 8-ohm load.

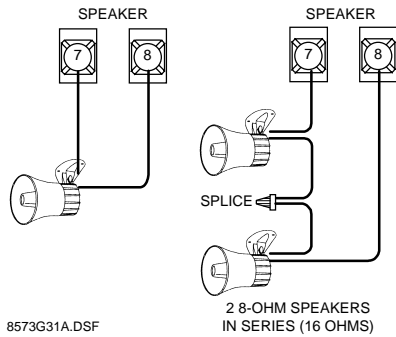

Connect speakers to the panel as shown in Figure 2-12.

FIGURE 2-12. Connecting the 15-watt Speaker to the Control Panel.

Connecting a Hardwire Interior Speaker

This task illustrates wiring the hardwire interior speaker to the Concord panel.

CAUTION

Connect only the large speaker to panel terminals 7 and 8 as shown. The smaller speaker cannot handle the output of terminals 7 and 8 and should not be connected, to avoid damaging the speaker.

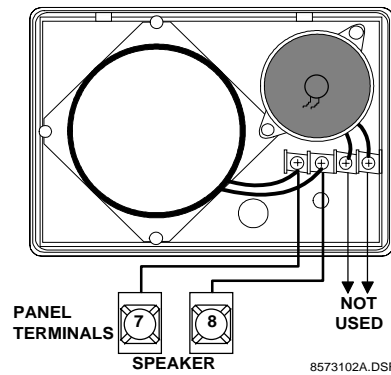

Connect speaker to the panel as shown in Figure 2-13.

FIGURE 2-13. Wiring the Hardwire Interior Speaker to the Panel.

Connecting the Hardwire Exterior Siren (13-046)

This task illustrates wiring the hardwire exterior siren to the Concord panel.

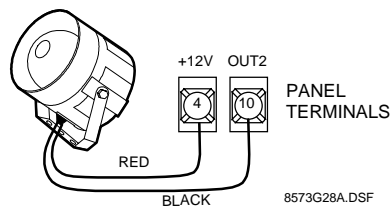

Connect siren to the panel as shown in Figure 2-14.

FIGURE 2-14. Wiring the Hardwire Exterior Speaker to the Panel.

Connecting the Slim Line Hardwire Interior Siren (60-483-01)

This task illustrates wiring the slim line hardwire interior siren to the Concord panel.

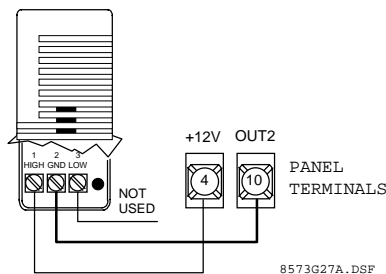

Connect siren to the panel as shown in Figure 2-15.

FIGURE 2-15. Wiring the Slim Line Interior Siren to the Panel.

Connecting SuperBus Phone Interface/Voice Module (60-777)

This task illustrates wiring the optional Phone Interface/Voice module to the Concord panel.

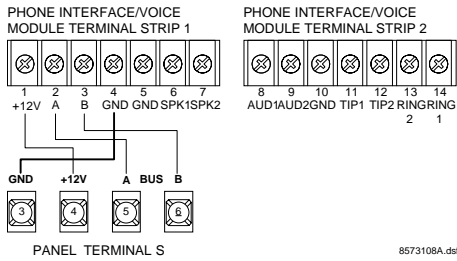

FIGURE 2-16. Wiring the Power and Bus Terminals.

1. Connect the module to the panel power and bus terminals as shown in Figure 2-16.

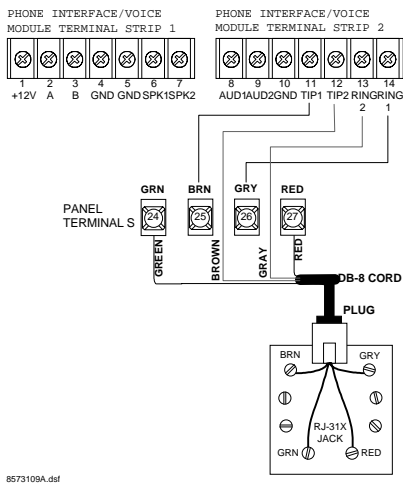

FIGURE 2-17. Wiring the Phone Connection.

2. Connect the phone line to the module through the panel terminals and DB-8 cord (from an RJ-31X jack as shown in Figure 2-17).

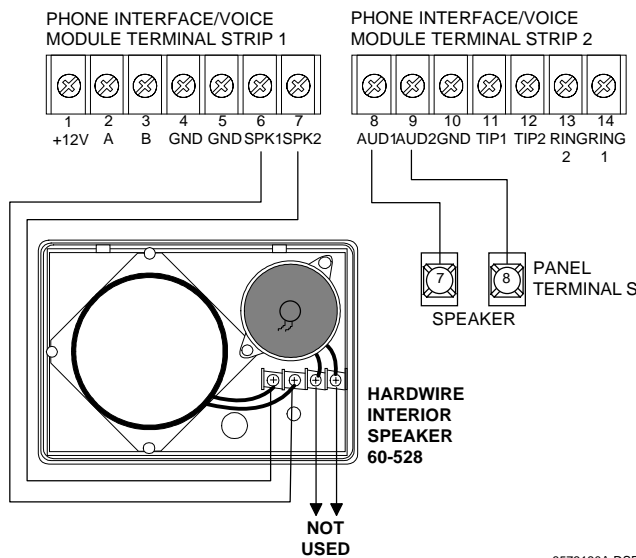

FIGURE 2-18. Wiring the Hardwire Interior Speaker.

3. Connect an interior speaker to the module terminals as shown in Figure 2-18.

When connected as shown, the speaker produces both voice messages and alarm sounds.

NOTE

To prevent voice messages from being heard outside, do not connect exterior speakers to module terminals 8 and 9.

Connecting SuperBus Energy Saver Module (ESM) (60-620)

This task illustrates wiring the optional Energy Saver module to the Concord panel.

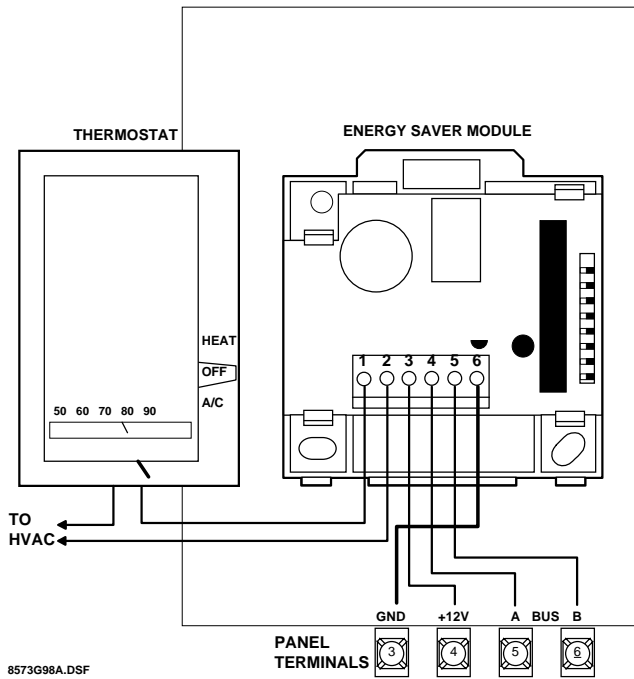

Connect the ESM to the panel and premises thermostat as shown in Figure 2-19.

FIGURE 2-19. Wiring the Energy Saver Module to the Panel.

Connecting SuperBus Hardwire Input Module (HIM) (60-584)

This task illustrates wiring the optional Hardwire Input Module (HIM) to the Concord panel.

Connect the HIM to the panel and detection loops as shown in Figure 2-20.

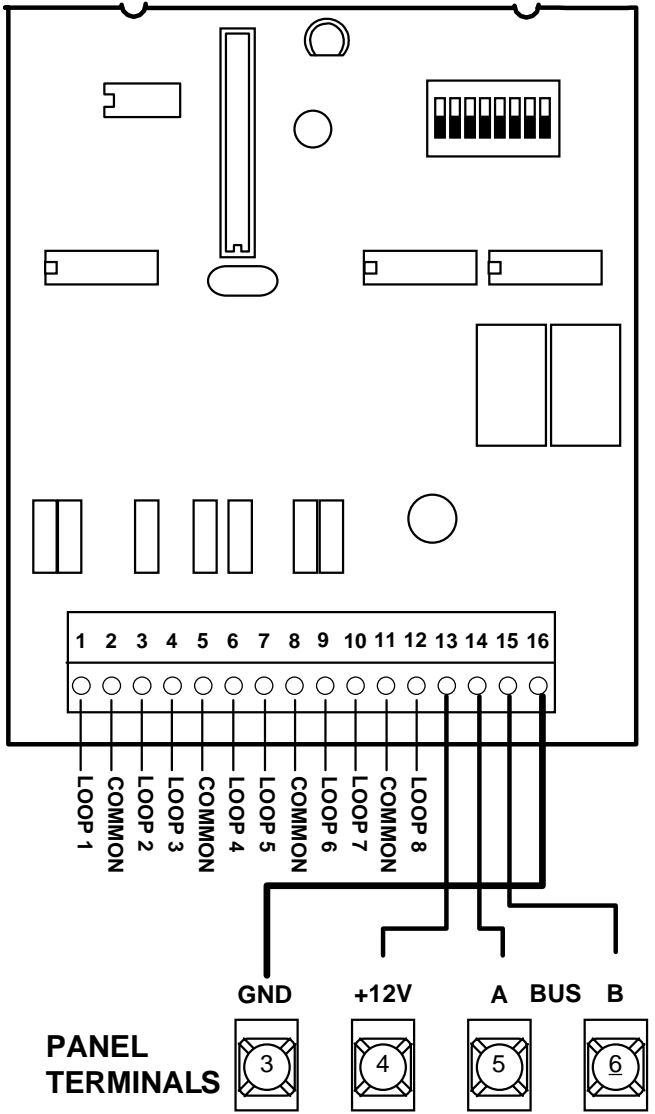

8573G99A.DSF

FIGURE 2-20. Wiring the SuperBus Hardwire Input Module (HIM) to the Panel.

Connecting SuperBus Hardwire Output Module (HOM) (60-585)

This task illustrates wiring the optional Hardwire Output module to the Concord panel.

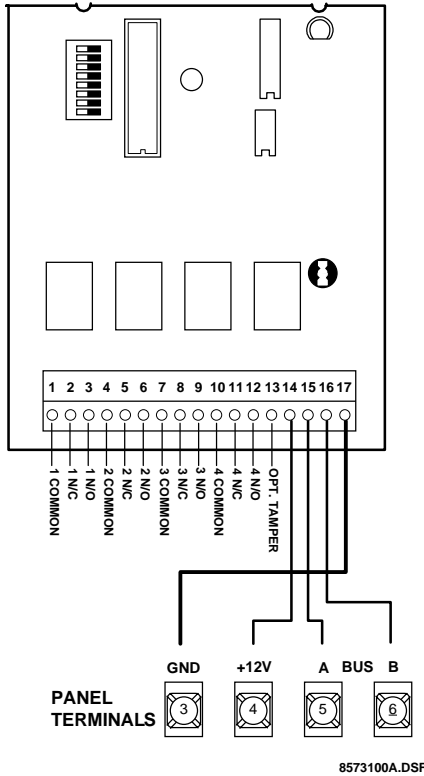

Connect the HOM to the panel and detection loops as shown in the figure at left.

FIGURE 2-21. Wiring the SuperBus Hardwire Output Module (HOM) to the Panel.

Connecting SuperBus RF Receiver (60-764-95R)

This task illustrates wiring the optional Hardwire Output module to the Concord panel.

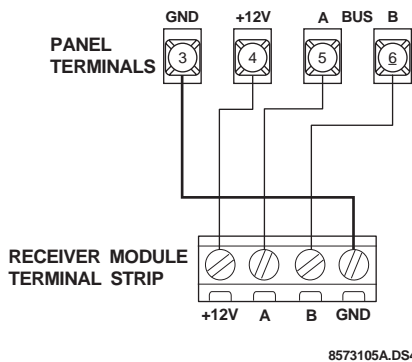

Connect the receiver module to the panel and as shown in the figure at left.

FIGURE 2-22. Wiring the SuperBus RF Receiver to the Panel.

Setting Unit Number DIP Switches on Bus Devices

This task illustrates setting the DIP switches on Bus Devices.

All bus devices must be set with a different unit number. While all alphanumeric touchpad unit numbers are set with the panel in normal operation mode, the following bus devices use DIP switches for setting the unit number (or address):

- SuperBus LED Touchpad
- SuperBus RF Receiver
- SuperBus Hardwire Input Module (HIM)
- SuperBus Hardwire Output Module (HOM)
- SuperBus Phone Interface/Voice Module
- Energy Saver Module

Use the following guidelines when setting unit number DIP switches:

- Each device connected to the panel's hardwire bus must be assigned a unique (different) unit number from 0-15.
- Hardwire Input Modules have eight DIP switches, of which only 5 through 8 are used to set the unit number.
- RF Receivers have four DIP switches.
- LED Touchpads have just 2 DIP switches and can be set for unit numbers 0-3 (factory set to 0).
- Alphanumeric touchpad unit numbers (factory set to 1) are changed in software during programming.
- Bus devices with identical (conflicting) unit numbers will not function correctly.
- All bus modules with DIP switches are shipped from the factory set to 0. For installations where only one of these devices is installed in addition to one alphanumeric touchpad, the factory setting of 0 can be used.
- If more than one alphanumeric touchpad is being installed, start with just one connected to the panel. Change touchpad unit numbers (DA or device address) after all system programming is completed, as described in the "Programming" section of this manual.

To set the unit number on LED Touchpads and bus modules with DIP switches:

Set the unit number DIP switches to the desired unit number as shown in the DIP switch setting tables below. Remember, each bus device must have a different unit number setting to work correctly.

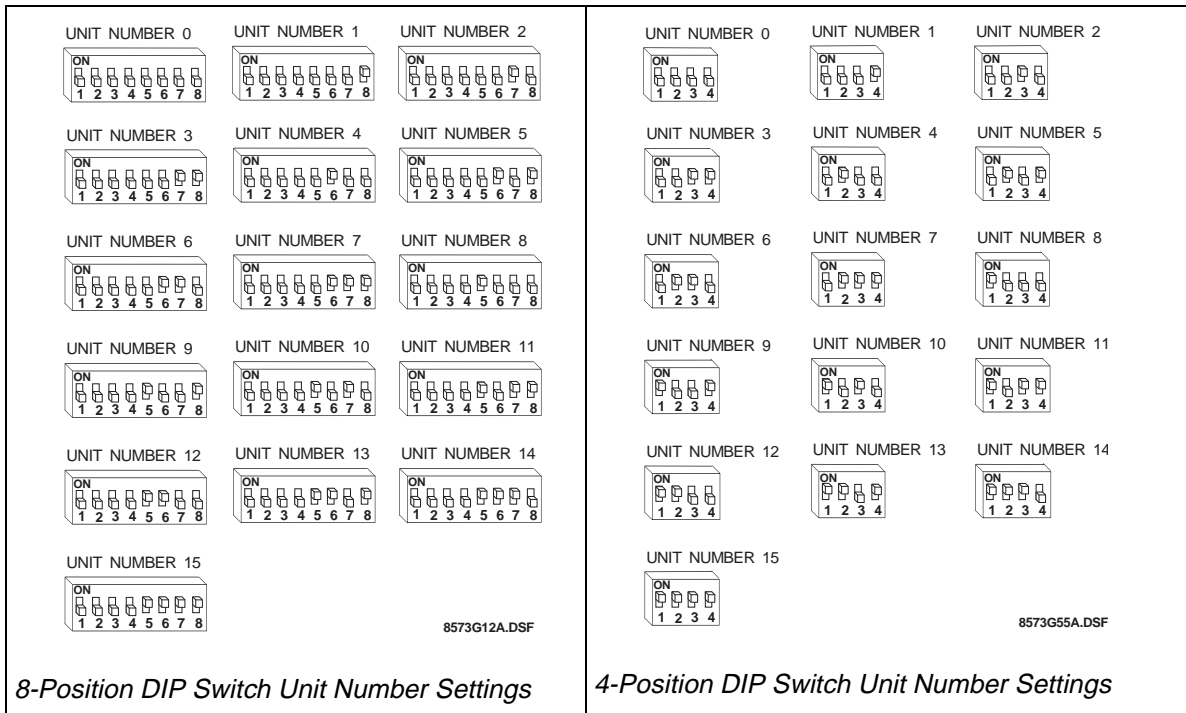

8-Position DIP Switch Unit Number Settings

4-Position DIP Switch Unit Number Settings

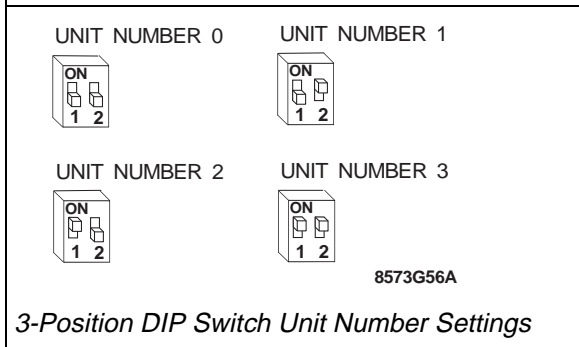

Student Notes:

Connecting Alphanumeric and LED Touchpads (60-728 and 60-746)

This task illustrates connecting touchpads to the Concord panel.

1. Disconnect the panel's transformer and backup battery.
2. Run a 4-conductor, 18- to 22-gauge wire from the panel to the touchpad location.
3. Splice the 4-conductor cable wires to the red, black, green, and white wires located on the back of the touchpad.
4. Connect the touchpad wiring to the panel terminals
Figure 2-23.

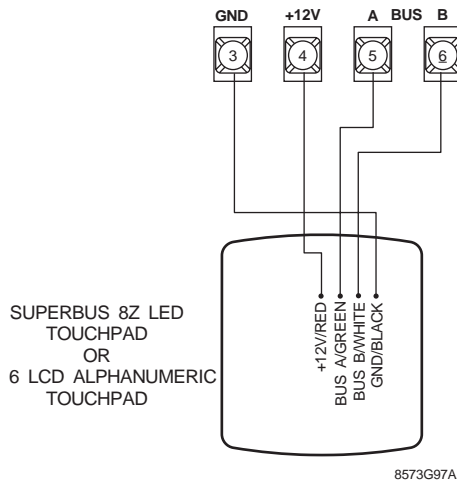

FIGURE 2-23. Wiring the Touchpad to the Panel.

Student Notes:

Connecting Phone Lines to the Panel

This task demonstrates connecting the Concord panel to the phone line using DB-8 cord.

A DB-8 cord (included with panel) uses a plug at one end for connecting to the RJ-31X module and flying leads on the other end for panel terminal connections.

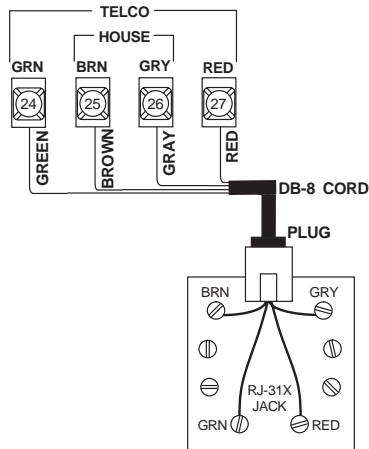

1. Connect the green, brown, gray, and red flying leads from the DB-8 cord to panel terminals 24, 25, 26, and 27.

FIGURE 2-24. Wiring the Cord to the Panel and RJ Jack.

NOTE

If you are using a PIV module, follow the instructions provided with it for phone line connections.

2. Insert the DB-8 cord's plug into the RJ-31X.
3. Check the phones on the premises for dial tone and the ability to dial out and make phone calls. If phones do not work correctly, check all wiring and correct where necessary.

Connecting the AC Power Transformer (60-761)

This task illustrates connecting the AC Power Transformer to the Concord panel.

CAUTION

Do not plug in the power transformer at this time. The panel must be powered up using the sequence of steps described in the following section, "Power Up the Panel."

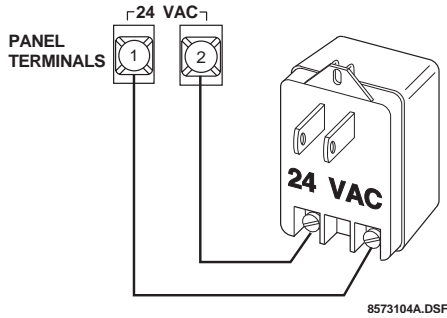

1. The panel must be powered by a plug-in step-down transformer that supplies 24 VAC, 30 VA (60-761) or 24 VAC, 50 VA (60-778).
2. For systems installed with the PLC module, Supervised Wireless Sirens, and X-10 Lamp Modules for light control, install the Line Carrier Transformer that supplies 24 VAC, 30 mA (60-762).
3. Connect the power transformer to the panel as shown in Figure 2-25.

FIGURE 2-25. Connecting the Transformer to the Panel Terminals.

Powering Up the Panel

This task demonstrates powering up the Concord panel after you've wired it.

CAUTION

You must connect and wire all devices to the panel and set all unit numbers on bus devices before applying AC and backup battery power to the panel.

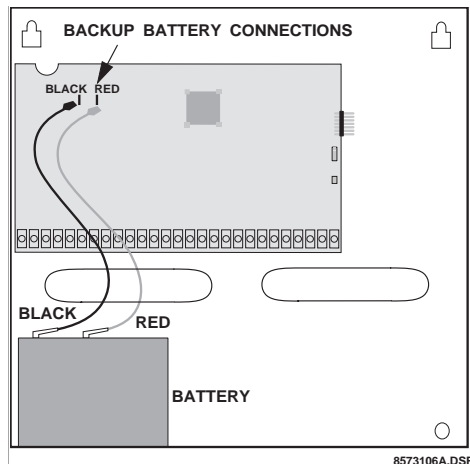

1. Connect the red (+) and black (-) battery leads (included with panel) to the + and - lugs located in the upper-left area of the panel circuit board (see Figure 2-26).
2. Connect the other ends of the battery leads to the battery terminals.
3. Verify that all wiring is correct and that there are no loose wires.
4. Plug the transformer into an outlet that is not controlled by a switch.
5. Alphanumeric touchpads show a date and time display.

If alphanumeric touchpads don't display anything, immediately unplug the transformer and disconnect the backup battery. Refer to "Troubleshooting" section.

FIGURE 2-26. Connecting the Backup Battery to the Panel.

6. To permanently mount the transformer, unplug it and remove the existing screw securing the AC outlet cover.

WARNING

Use extreme caution when securing the transformer to a metal outlet cover. You could receive a serious shock if a metal outlet cover drops down onto the prongs of the plug while you are securing the transformer and cover to the outlet box.

7. Hold the outlet cover in place and plug the transformer into the lower receptacle.
8. Use the screw supplied with the transformer to secure the transformer to the outlet cover.

CONCORD
Installation

Module 3-Peripheral Installation

Introduction

This module teaches the installer how to install wireless peripheral devices for the Concord system.

What's in This Module

Locating Wireless Sensors	3-2
Installing the Door/Window Sensor (60-362).....	3-5
Installing the Slim Line Door/Window Sensor (60-499)	3-6
Installing the Micro Recessed Door/Window Sensor (60-741-95)	3-7
Connecting 2-Wire Smoke Detectors	3-8
Installing the 2100 (60-506-319.5) and 2300 (60-645-95) Smoke Sensors	3-9
Installing the IntelliSense Sound Sensor (60-582).....	3-10
Installing the Rate of Rise Heat Sensor (60-460)	3-13
Installing the PIR Wall Mount Motion Sensor (60-511)	3-14
Installing the Shock Sensor (60-461).....	3-15
Installing the Supervised Wireless Interior Siren (60-736-95)	3-15
Installing the X-10 Lamp Control Module (13-204)	3-16

Locating Wireless Sensors

This table provides tips for finding the best locations for wireless sensors.

Sensor	Do	Don't
All Sensors	<ul style="list-style-type: none"> Try to keep all sensors within 150 feet of the CPU. The 150 foot distance recommendation is given as a starting guide line. The panel has an open air range of at least 1500 feet, but the installation environment will influence this range. 	<ul style="list-style-type: none"> Place sensors or magnets on any metallic surface such as metal doors or foil wallpaper. If you must, then use spacers to keep sensor and magnet away from the metal. Place sensors in areas with excessive metal or electrical wiring, such as furnace/utility rooms. Place sensors in areas where they will be exposed to moisture. Place sensors in locations where the temperature will exceed the sensor's operating limits of 10 to 120 ° F.

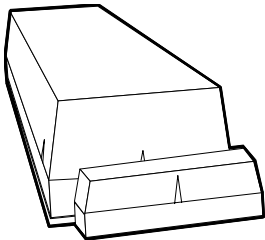
Sensor	Do	Don't
Door/Window Sensors 60-362 and 60-499 	<ul style="list-style-type: none"> Mount the sensor on the door frame (magnet on the door or on double doors, mount sensor on the least used door, magnet on the other door). Mount the sensors with screws, not double-sided tape. 	<ul style="list-style-type: none"> Place sensors on a door within 5 inches of the floor to avoid damage to sensors.

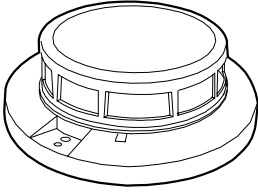
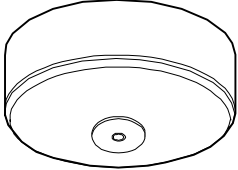
Sensor	Do	Don't
<p>Smoke Sensor 60-645</p> 	<ul style="list-style-type: none"> • Determine the best locations for each Smoke Sensor to optimize early detection and maintain accessible escape routes out of the building. • Locate a Smoke Sensor at the bottom of the basement stairwell(s). For other stairwells, locate Smoke Sensors at top of the stairwell. • Mount sensors on ceilings whenever possible. Make sure that the Smoke Sensor is no closer than 4" to any wall. • Place the Smoke Sensor no more than 6" from ceiling for wall mounting. • Locate the Smoke Sensor in any hallway servicing bedrooms. For maximum protection, place a Smoke Sensor inside each bedroom, especially smokers' bedrooms or rooms where electric blankets and electrical devices are used. 	<ul style="list-style-type: none"> • Mount smoke sensors in rooms with sloped, peaked, or gabled ceilings whenever possible. If unavoidable, mount detector(s) within 3 feet (measured horizontally) from the highest point of the ceiling. • Mount smoke sensor in or near damp or very humid areas such as bathrooms with showers. • Install near fluorescent light fixtures. Noise from electrical lights may cause nuisance alarms. • Place sensors in location where the temperature will exceed the Smoke Sensor's operating limits of 40° to 100°F. • Mount in very dusty or dirty areas. • Mount near fresh air inlets or returns or excessively drafty areas. • Mount in areas where many insects are present.
Sensor	Do	Don't
<p>Rate of Rise Heat Sensor 60-460</p> 	<p>Use heat detector to protect property. Also use smoke detectors where life safety is involved.</p> <p>Mount sensors within 150 feet of CPU.</p> <p>Ceiling mounting near the center of the area to be protected is recommended. Do not mount within 4 inches of a wall.</p> <p>If wall mounting, the top of the detector must be within 4 to 6 inches of the ceiling.</p>	<p>Mount where ceiling temperatures exceed 100° F.</p> <p>Mount a Rate-of-Rise Sensor too close to something that changes temperature rapidly, for example, above an oven or near a heat duct, furnace or boiler.</p>

CONCORD
Peripheral Installation

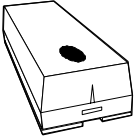
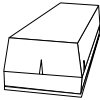
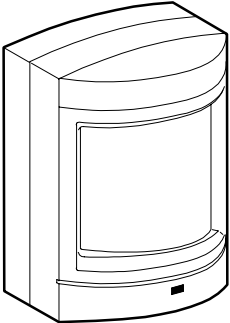
Sensor	Do	Don't
<p>Freeze Sensor 60-504</p> 	<ul style="list-style-type: none"> • Locate the sensor in an area that is likely to get cold first. • Locate the sensor on an interior wall where there is free movement of air. 	<ul style="list-style-type: none"> • Locate the sensor in the same room as a furnace, water heater, or any other heat source that may stay warm after the furnace fails. • Locate the sensor on an outside wall or near the basement floor.
<p>Glass Guard Sensor 60-462</p> 	<ul style="list-style-type: none"> • Mount sensor on glass at least 1-inch from the frame. • Mount sensor on a fixed pane of glass. 	<ul style="list-style-type: none"> • Use more than four additional devices in series with the sensor.
<p>PIR Motion 60-511</p> 	<ul style="list-style-type: none"> • Mount so there is a reference point (such as a wall) at the end of its detection pattern. • Mount so that an intruder will most likely walk across the detection pattern. • Mount 5 to 8 feet above the floor. • Mount on an insulated outside wall facing in. • Mount on a surface that is rigid and free from vibration. 	<ul style="list-style-type: none"> • Mount in direct sunlight. • Aim at air conditioners, heat vents, wood stoves, fireplaces, or any intermittent heat source. • Aim at solar heated walls or uninsulated metal walls. • Aim at moving objects. • Mount in an area where the coverage may be blocked by any temporary items such as boxes or freight.

Installing the Door/Window Sensor (60-362)

This task illustrates installing the door/window sensor. For programming and testing instructions, refer to the *Concord Security System Reference Manual* or the corresponding Concord training module.

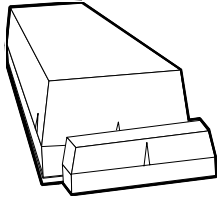

NOTE

It is important to be free of all static electricity when handling sensor circuit boards. Touch a grounded metal surface before handling the circuit board.

Always handle the circuit board by the edges and never set the circuit board on any metallic surface.

NOTE

The sensor base has markings that indicate the position of the reed switches when the circuit board is reinstalled.

Use the markings for aid in alignment. Spacers are available if the sensor will be mounted on a metallic surface or height alignment is needed.

NOTE

Ensure the magnet won't interfere with door or window opening. Do not use two sided tape to mount magnet.

NOTE

After determining which reed switch will be used, remove the other reed switch by clipping the leads as close to the board as possible.

1. Remove the sensor cover by pressing on the end of the cover (that has an opening for wire) to release the tab on the cover from the slot on the sensor base.
2. Carefully remove the circuit board by pulling back on the tab and lifting the battery holder, or gently flex the plastic sensor base to release the circuit board. To guard against static, place circuit board in sensor cover before continuing.
3. Mount the sensor base using #6 flathead screws. Two screw holes are provided, one is enlarged to allow for sensor alignment. Two small additional holes are provided for mounting the sensor with 18 gauge wire nails (brads) and a brad driver.
4. Mount magnet base within 3/8-inch of the sensor's base, centered on the base's notch or tab. Use two #6 x 1/2-inch flathead screws.
5. Reattach the circuit board to the sensor base.
6. Reattach the sensor cover to the sensor base.

Installing the Slim Line Door/Window Sensor (60-499)

This task covers installing the slim line door/window sensor. For programming and testing instructions, refer to the *Concord Security System Reference Manual* or the corresponding Concord training module.

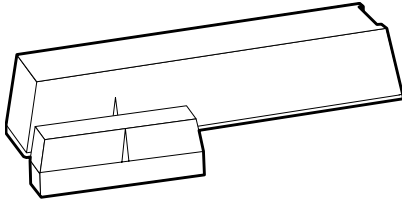

NOTE

The notch on the sensor base indicates the reed switch position when the circuit board is installed.

NOTE

Ensure the magnet won't interfere with the door or window opening. Don't use two-sided tape to mount magnet.

1. Remove the sensor cover by pressing on the cover release catch.

2. Mount the sensor base. Two screw holes are provided, one is enlarged to allow for sensor alignment.

Use #4 x 1-inch pan head screws when mounting the sensor.

Two small additional holes are provided for mounting the sensor with 18 gauge wire nails (brads) and a brad driver.

3. Mount the magnet base within 3/8-inch of the sensor's base, centered on the notch. Use two #4 x 1-inch pan head screws or #18 x 1/2-inch wire nails.

4. Remove the spring from the accessory pack and place on the tamper switch.

5. Replace the sensor cover, while positioning the tamper spring to protrude through the hole in the sensor base.

The tamper switch detects removal of the cover or removal of the sensor from the wall.

Installing the Micro Recessed Door/Window Sensor (60-741-95)

This task details installing the recessed door/window sensor. For programming and testing instructions, refer to the *Concord Security System Reference Manual* or the corresponding Concord training module.

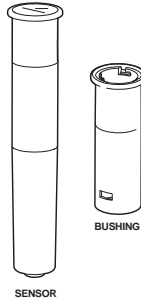

1. Program the recessed door/window sensor and perform a dealer sensor test before installing the sensor.

To simulate mounting, test the transmitter by holding it on the exterior side of the door frame and then tripping it.

2. Using a 5/8-inch spade or paddle bit, drill a hole to the minimum depth of 3³/₄-inches in the door or the window frame.
3. Slide the transmitter tube into the hole. The lip of the tube should fit snugly against the door frame surface.
4. Perform a dealer sensor test to verify that the transmitter is still working.
5. Drill a 1/2-inch diameter hole for mounting the magnet in wood. The hole should be 2-inch deep and centered on the opposite transmitter hole.
6. Place the magnet in the hole. It should fit tightly. If it doesn't fit tightly, secure it with adhesive.
7. Perform a customer sensor test to be sure the sensor and magnet are aligned properly.

Installing the Magnet

NOTE

Ensure the magnet doesn't interfere with the door or window opening.

Connecting 2-Wire Smoke Detectors

This task illustrates connecting 2-wire smoke detectors to the Concord panel.

Zone input 8 can be set up (in program mode) to accept 12 VDC, 2-wire smoke detectors by the following manufacturers:

- System Sensor models 2100, 2100T, 2400, 2400T
- Sentrol models 429C, 429CT, 521B, 521BXT

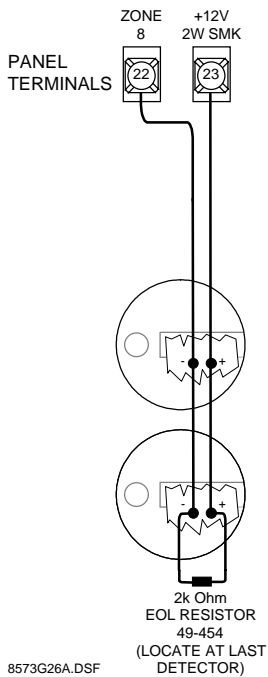

When zone input 8 is configured for 2-wire smoke detectors, the maximum allowed loop current draw is 100 mA (in alarm).

Connect up to ten 2-wire smoke detectors to the panel as shown in Figure 3-1

NOTE

Note: Zone 8 must have the 2-wire smoke option turned on for 2-wire smoke detectors to operate correctly, when connected to the zone 8 input. See *ONBOARD OPTIONS—INPUTS* in the “Programming” section for complete details.

FIGURE 3-1. Connecting 2-wire Smoke Detectors.

Installing the 2100 (60-506-319.5) and 2300 (60-645-95) Smoke Sensors

This task details installing the 2100 and 2300 Smoke Sensors. For programming and testing instructions, refer to the *Concord Security System Reference Manual*.

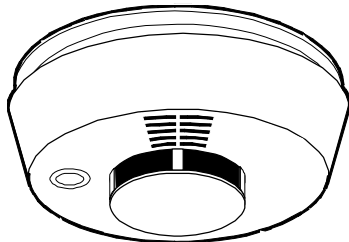

Model 2100

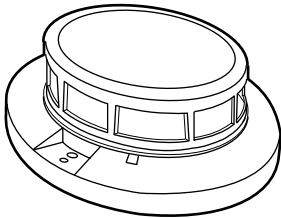

8862G04A.DS4

Model 2300

1. Remove the sensor mounting bracket.
2. Mount bracket directly onto wood surfaces using #8, 1 ½-inch wood screws. If you mount it to plaster or dry-wall, use appropriate anchors.
3. Insert the batteries and look for proper polarity.
4. Place the sensor in the mounting bracket by aligning the arrows on the mounting bracket and smoke detector.

Installing the IntelliSense Sound Sensor (60-582)

This task illustrates installing the IntelliSense Sound Sensor. For programming and testing instructions, refer to the *Concord Security System Reference Manual* or the corresponding Concord training module.

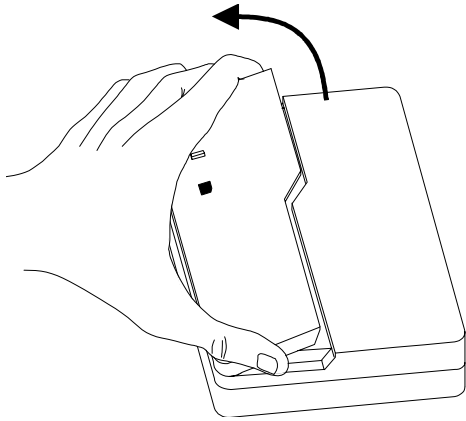

1. Open the sensor door by grasping it at the top and bottom with one hand and pulling upward.

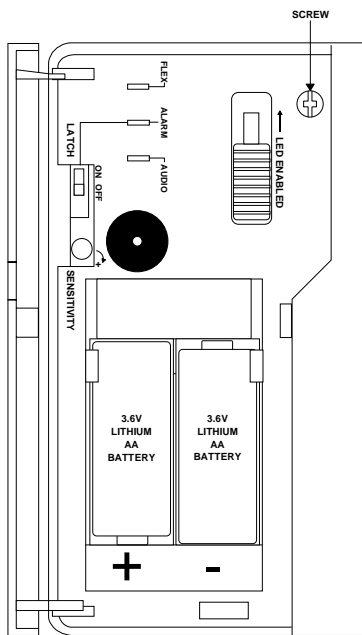

2. Remove the sensor cover screw using a Phillips screwdriver.

3. Remove the sensor cover by first pulling up at the top of the cover, then lift up at the bottom.

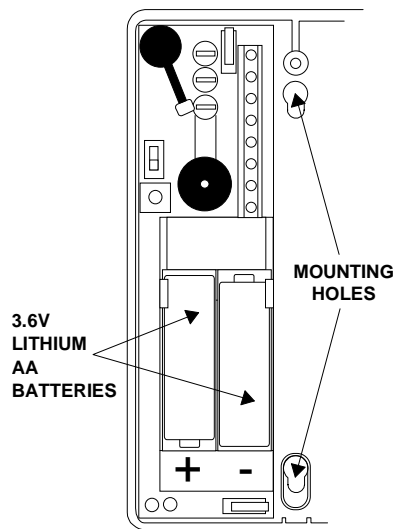

4. Place the sensor base on the desired location on the wall or ceiling and mark the narrow portion of the mounting holes. See Figure 3-2.

FIGURE 3-2. Mounting Hole Locations.

NOTE

Use anchors if installing in plaster or drywall.

NOTE

Do not bend the tamper switch lever while installing the cover.

5. Insert screws part way the wall.

6. Place the sensor base on the screws and slide the narrow portion of the mounting holes onto the screws.

7. Gently tighten the screws to secure the sensor in place.

8. Before attaching the sensor cover to the sensor, first close the door on the sensor cover.

9. Align the top edge of the cover and base, then swing the cover down in the direction of the arrow.

10. Carefully open the door and while holding the cover in place, install the sensor cover screw.

Adjusting the Flex Sensitivity

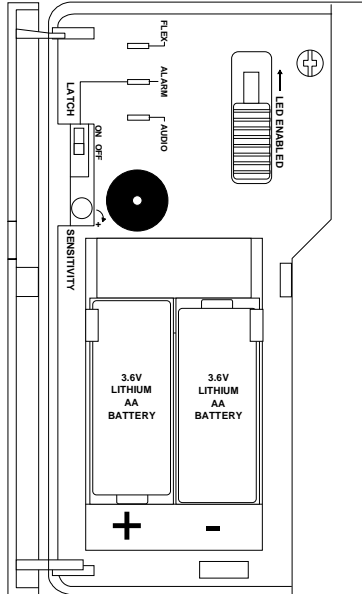

1. Open the sensor door and slide the orange LED ENABLE switch in the direction of the arrow. An orange tab protrudes from the side of the sensor to indicate the LEDs are active.

2. Using a small pocket screwdriver, increase the sensitivity by turning the sensitivity control completely clockwise (maximum).
3. Close the sensor door.
4. Turn on any heating/air-conditioning system, and any other equipment in the sensor's vicinity.

Observe the yellow flex LED for one minute with equipment running. Excessive subsonic (inaudible) noise typically produced by air handling systems may cause the flex LED to flash randomly.

5. If the flex LED flashes randomly, decrease the sensitivity by turning the sensitivity control counterclockwise just until the flashing stops.

Testing the Audio and Flex Ranges

NOTE

For UL listed systems, the installer should test the unit at least once a year.

1. Hold the tester at the farthest point of the glass to be protected (25-foot maximum).
2. Activate the tester in the manual mode. If the green LED on the sensor flashes, the audio microphone will detect breaking glass at that distance.

Testing the Flex Range

1. Set the tester to the flex mode and press the red button to arm the simulator.
2. Within 30 seconds of arming the tester, generate a flex signal by striking the glass with your hand or a cushioned tool.
3. The tester will automatically generate a burst of glass-break sound, and the sensor's red LED should light indicating an alarm condition.
4. Open the sensor door and slide the orange LED ENABLE switch back to its normal position.

Installing the Rate of Rise Heat Sensor (60-460)

This task details installing the rate of rise heat sensor. For programming and testing instructions, refer to the *Concord Security System Reference Manual* or the corresponding Concord training module.

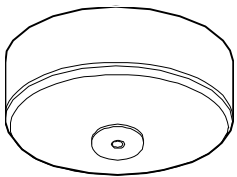

NOTE

Use anchors if installing in plaster or drywall.

1. Remove the sensor's mounting bracket.
2. Mount bracket directly onto wood surfaces using #8, 1 ½-inch wood screws.
3. Insert batteries and look for proper polarity.
4. Place the sensor in the mounting bracket by aligning the arrows on the mounting bracket and heat sensor.

Installing the PIR Wall Mount Motion Sensor (60-511)

This task details installing the DS924 motion detector (PIR). For programming and testing instructions, refer to the *Concord Security System Reference Manual* or the corresponding Concord training module.

Mounting without Swivel Bracket

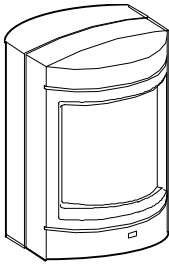

PIR MOTION

NOTE

If you are mounting the base in drywall or plaster, first drill a 1/8-inch pilot hole. This will help you determine what type of material is behind the surface and whether to use a drywall anchor or the #6 x 1-inch wood screw.

Mounting with the Swivel Bracket

NOTE

If you are mounting the base in drywall or plaster, first drill a 1/8" pilot hole. This will help you determine what type of material is behind the surface and whether to use a drywall anchor or the #6 x 1" wood screw.

You can mount the PIR with the swivel bracket or without.

1. Remove the mounting plate by gently pushing in with your thumb and prying it away from the PIR body.
2. Remove the PIR cover.
3. Secure the mounting plate using either of the corner-mount knock outs that fit the mounting situation.
4. Place the PIR body into the mounting plate and secure it to the mounting plate using the mounting plate screw.
5. Set the pulse sensitivity. See the DS924 instructions for more information.
6. Remove the mounting plate by gently pushing in with your thumb and prying it away from the PIR base.
7. Mount the swivel bracket with the #6 x 1-inch wood screw for the corner mount or flat surface oriented with the hallway.
8. Using the #6 x 5/8-inch metal screw secure mounting plate to the swivel bracket. Tighten the screw until snug. Do not fully tighten the screw yet.
9. Replace PIR base into mounting plate. Check the PIR for correct alignment. When done gently remove the PIR base from the mounting plate and fully tighten the metal screw in the swivel bracket.
10. Replace the PIR base into the mounting plate and secure it to the mounting plate with the mounting plate screw.

Installing the Shock Sensor (60-461)

This task details installing the shock sensor. For programming and testing instructions, refer to the *Concord Security System Reference Manual* or the corresponding Concord training module.

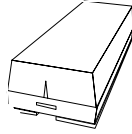

NOTE

If only the self-contained reed switches will be used, place a jumper between terminals 2 and 3 on the transmitter circuit board.

NOTE

If you are mounting the base in drywall or plaster, first drill a 1/8-inch pilot hole. This will help you determine what type of material is behind the surface and whether to use a drywall anchor or the #6 x 1-inch wood screw.

1. Remove the sensor cover to disengage the top of the cover from the slot in the sensor base.
2. Secure the sensor using the two screw holes in the base.
One hole is larger to allow alignment of the sensor.
3. Put the sensor circuit board back into place, sliding the reed-switch end in first then snapping the board in place. Be sure the locking tab is secure and the board is level.

Installing the Supervised Wireless Interior Siren (60-736-95)

This task illustrates installing the Supervised Wireless Interior Siren (SWIS). For programming and testing instructions, refer to the *Concord Security System Reference Manual* or the corresponding Concord training module.

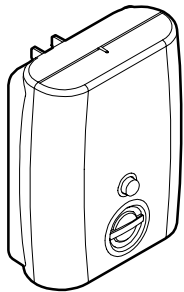

8555G01A.DSF

NOTE

When installing supervised wireless sirens for supervised operation, be sure to program sensor text that clearly identifies each siren. For example, **HALLWAY SIREN** or **BASEMENT SIREN**. This can help both you and your customer locate a specific siren if a problem occurs.

1. Power up the panel.
2. Install the siren backup battery.
3. Enter program mode and set the partition House Code to the desired setting.
4. Proceed to the *SIREN OPTIONS* menu and set the SWS Supervision Code to the desired setting.
5. Proceed to the *LEARN SENSORS* menu and select the desired partition, sensor group 33, and the desired sensor number.
6. When the touchpad display shows *TRIP SENSOR nn*, plug the siren into an electrical outlet. The siren should beep once and the siren's LED should flash 10 times, indicating the panel learned the siren's transmitter ID and that the siren learned both the partition House Code and SWS Supervision Code.
7. Exit program mode.

Installing the X-10 Lamp Control Module (13-204)

This task illustrates installing the X-10 Lamp Module.

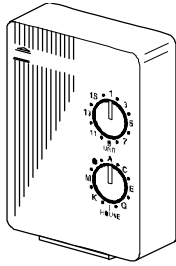

X-10 Lamp Module

1. Make sure the panel uses the Line Carrier Transformer (60-762 or 60-779).
2. Plug the lamp cord into the bottom of the X-10 Lamp Module.
3. Plug the X-10 Lamp Module into a lower AC outlet.
4. Set the house code on the X-10 Lamp Module.
 - Determine the house code that is programmed into the panel.
 - Find that house code on the following table.
 - Look to the left column of the table for the letter that corresponds to the house code.
 - For example, house code 105 corresponds to letter J.
 - Rotate the **House** dial to the corresponding letter.

TABLE 3-1. X-10 House Code Settings.

A		16	32	48	64	80	96	112	128	144	160	176	192	208	224	240
B	1	17	33	49	65	81	97	113	129	145	161	177	193	209	225	241
C	2	18	34	50	66	82	98	114	130	146	162	178	194	210	226	242
D	3	19	35	51	67	83	99	115	131	147	163	179	195	211	227	243
E	4	20	36	52	68	84	100	116	132	148	164	180	196	212	228	244
F	5	21	37	53	69	85	101	117	133	149	165	181	197	213	229	245
G	6	22	38	54	70	86	102	118	134	150	166	182	198	214	230	246
H	7	23	39	55	71	87	103	119	135	151	167	183	199	215	231	247
I	8	24	40	56	72	88	104	120	136	152	168	184	200	216	232	248
J	9	25	41	57	73	89	105	121	137	153	169	185	201	217	233	249
K	10	26	42	58	74	90	106	122	138	154	170	186	202	218	234	250
L	11	27	43	59	75	91	107	123	139	155	171	187	203	219	235	251
M	12	28	44	60	76	92	108	124	140	156	172	188	204	220	236	252
N	13	29	45	61	77	93	109	125	141	157	173	189	205	221	237	253
O	14	30	46	62	78	94	110	126	142	158	174	190	206	222	238	254
P	15	31	47	63	79	95	111	127	143	159	175	191	207	223	239	255

The system will turn on the lamp connected to the X-10 Lamp Module during entry and exit delays, police, auxiliary/medical, and fire alarms.

Module 4-Programming

Introduction

This module teaches the installer how to program the most commonly used features of the Concord system.

Using what they've learned here, installers should be able to complete other programming tasks not presented in this module using just the programming flowchart.

What's in This Module

Entering and Exiting Programming Mode.....	4-2
Exiting Programming Mode	4-2
Clearing Memory.....	4-3
Tour of the Concord Programming Menus	4-4
Navigating Through the Menus	4-5
Concord Programming Menus.....	4-6
Programming Shortcuts	4-11
Learning Sensors.....	4-37
Sensor Group Characteristics Table	4-39
Tripping Learn Mode Wireless Sensors	4-41
Viewing Sensor Information	4-43
Verifying the Bus Device Unit Numbers	4-45

Entering and Exiting Programming Mode

This task illustrates entering and exiting programming mode.

Entering Programming Mode

You must enter programming mode before you can program any of the system programming options.

NOTE

An alphanumeric touchpad must be used for programming.

1. Disarm the system.
2. Enter **8 + 4321 + 0 + 0**.

The system shows:

SYSTEM PROGRAMMING

Exiting Programming Mode

You must exit programming mode to place the system back in normal mode.

1. Press **A** or **B** until the system displays:

EXIT PROGRAMMING READY

2. Press **#**.

The system displays the day, date and time. This means the system is in Run mode.

Student Notes

Clearing Memory

This task illustrates clearing the Concord system memory. Clear the memory of newly installed panels before programming. Clearing the memory erases all settings in the system.

1. Enter program mode.
2. Press **B** until the system displays:

CLEAR MEMORY

3. Press **#**.

ENTER CODE TO
CLEAR MEMORY

4. Enter the installer code / dealer code. (Default 4321)
5. Press **#**.

The panel will clear the memory, exit program mode.

Tour of the Concord Programming Menus

This task illustrates navigating through the Concord programming tiers and menus.

The Concord menus are contained in two tiers: Tier 1 and Tier 2.

Tier 1 contains the following menus:

- System Programming
- Demo Kit
- Partition 1 Copy
- Clear Memory
- Exit Programming Ready

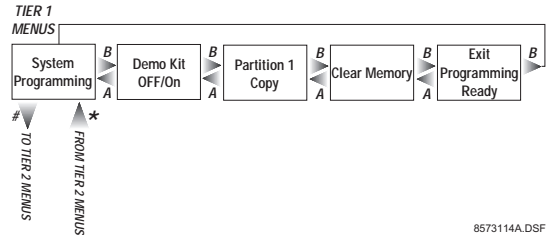

Tier 2 contains the following menus under the System Programming menu of Tier 1:

- Security
- Phones
- Phone Options
- Timers
- Light Control
- Touchpad Options
- Reporting
- Siren Options
- Sensors
- Audio Verification
- Accessory Modules
- Onboard Options
- Wireless Touchpads

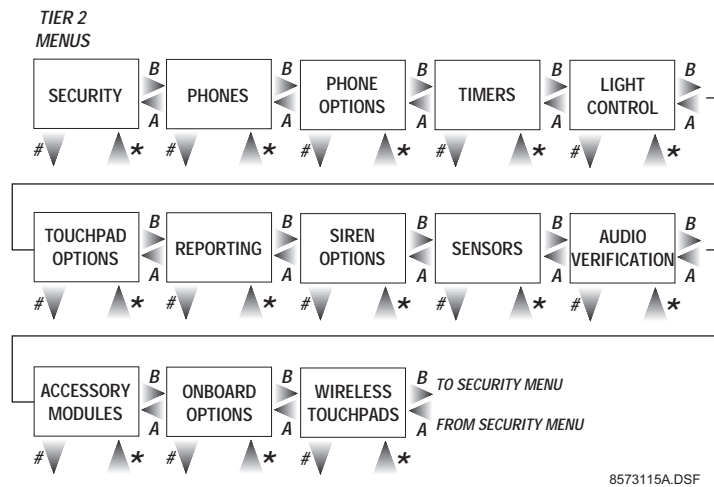

Navigating Through the Menus

Use the following touchpad buttons to navigate through the menus. Look at the programming chart while you are reviewing this 4-1.

TABLE 4-1. Concord Programming Navigation.

Button	Programming Function	Example
Numeric Buttons	Used to enter numeric values such as menu numbers, delay times and sensor numbers. Also used to enter text character and word codes during sensor text programming.	When you want to go to the Sensor menu and you are looking at the Security menu, press 08 + #
A	Scrolls backward to previous menu. Displays previous sensor text library character during sensor text programming.	When you want to move back to the Security menu and you are looking at the Phone Options menu, press A twice.
B	Scrolls forward to next menu on current tier. Displays next sensor text library character during sensor text programming.	When you want to move to the Touchpad Options menu and you are looking at the Security menu, press B four times.
C	Used to enter pauses when programming phone numbers.	When you need to program a pause in a phone number, use C .
D	Deletes programming for certain menu items.	
#	Used to move forward to next menu tier, and enter or accept displayed entry.	When you want to get into the Sensor menu and the touchpad shows, " <i>SENSORS</i> ", press # to open the Sensors menu.
*	Cancels and exits displayed programming command (if pressed before #). Backs out to previous menu tier.	When you are done programming sensors and you want to go back to the Sensor menu, press * as many times as needed until you see " <i>SENSOR</i> " displayed on the touchpad.

Concord Programming Menus

To enter Programming Mode,
8 + Installer or Dealer Code + 0 + 0

TIER 1 MENUS

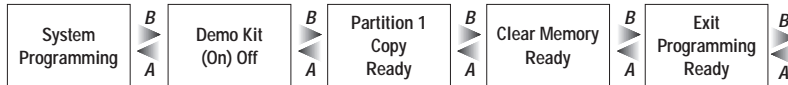

TIER 2 MENUS

Continued

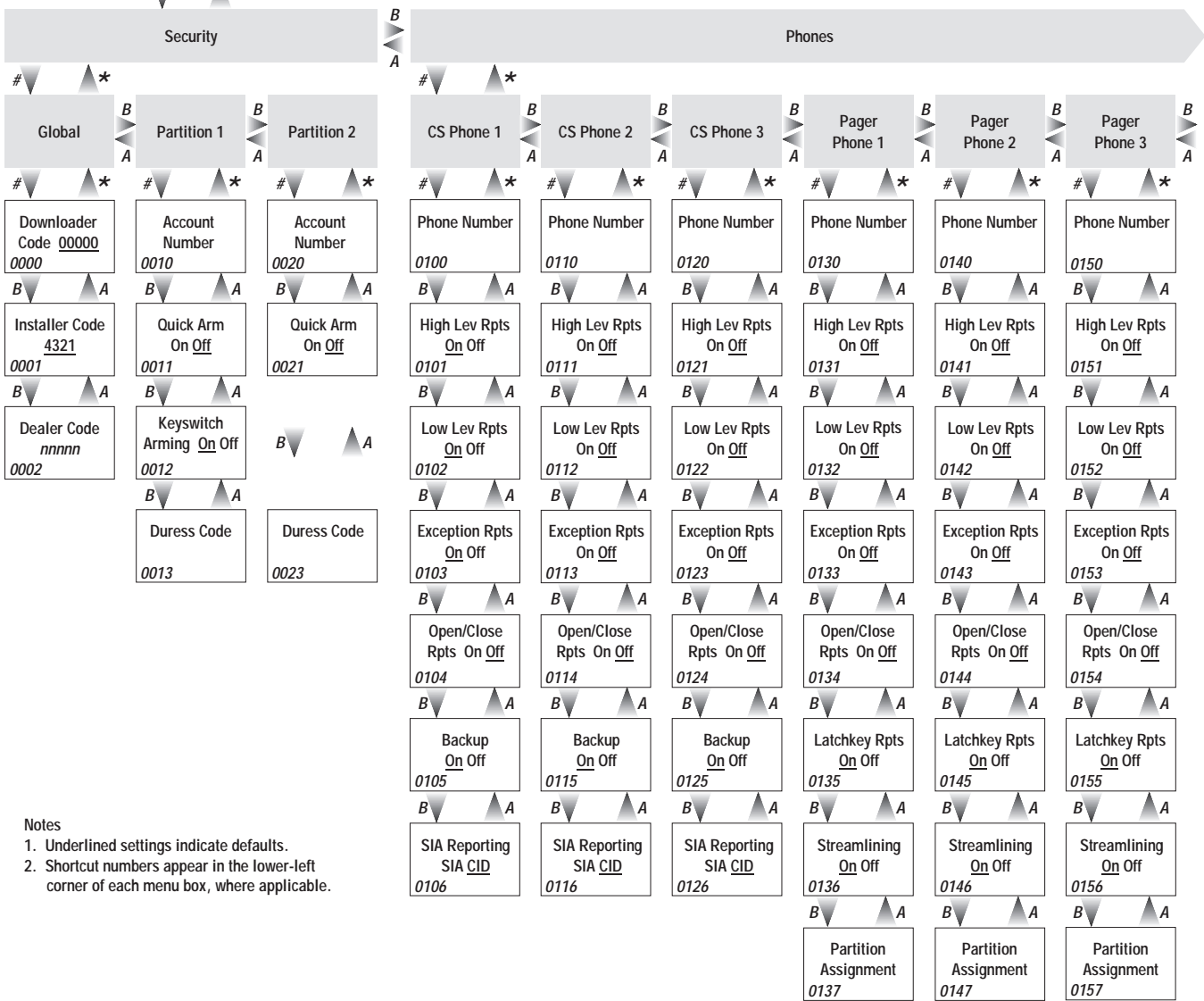

Notes

- Underlined settings indicate defaults.
- Shortcut numbers appear in the lower-left corner of each menu box, where applicable.

*Press B to
continue to
Light Control.*

TIER 2 MENUS

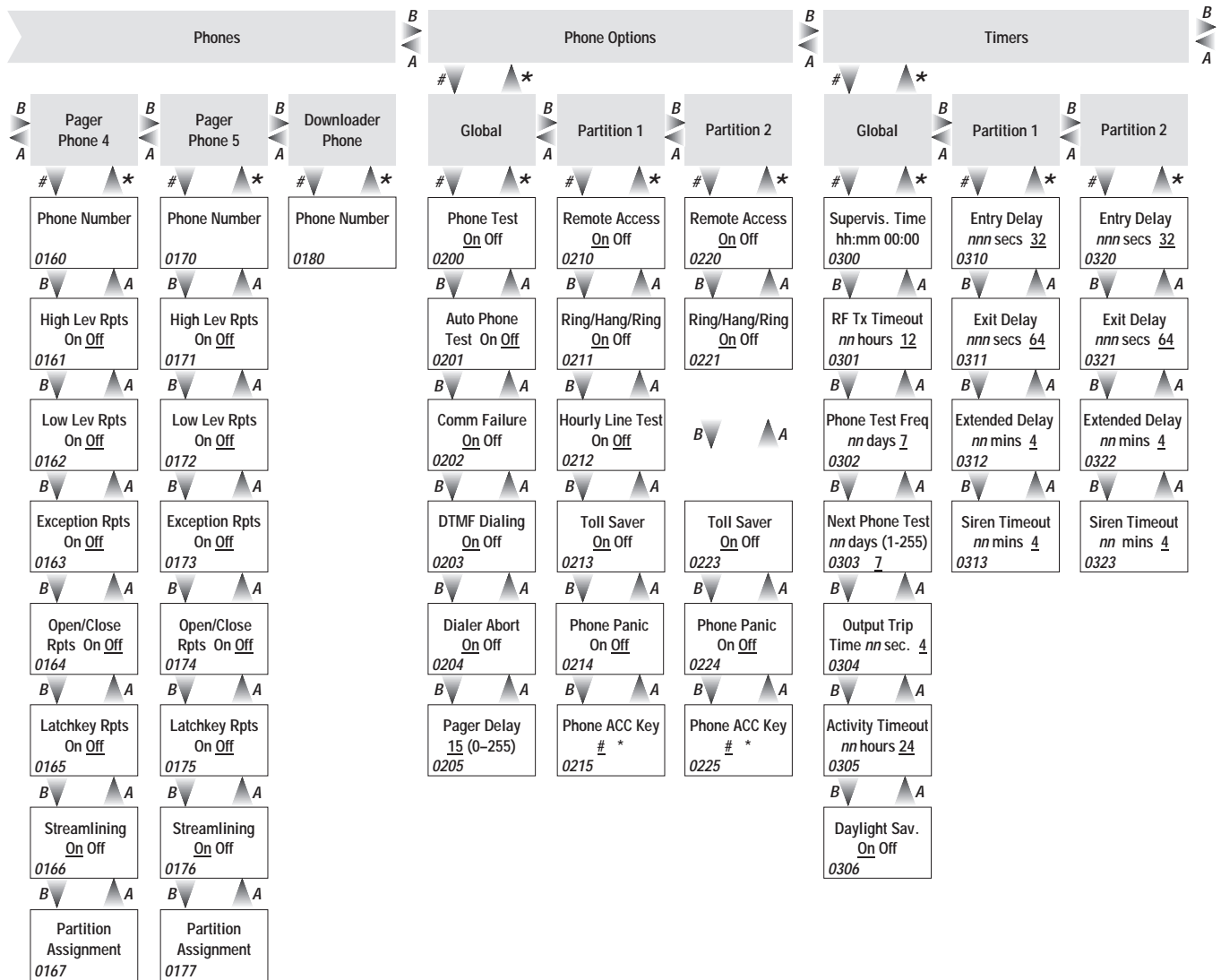

CONCORD Programming

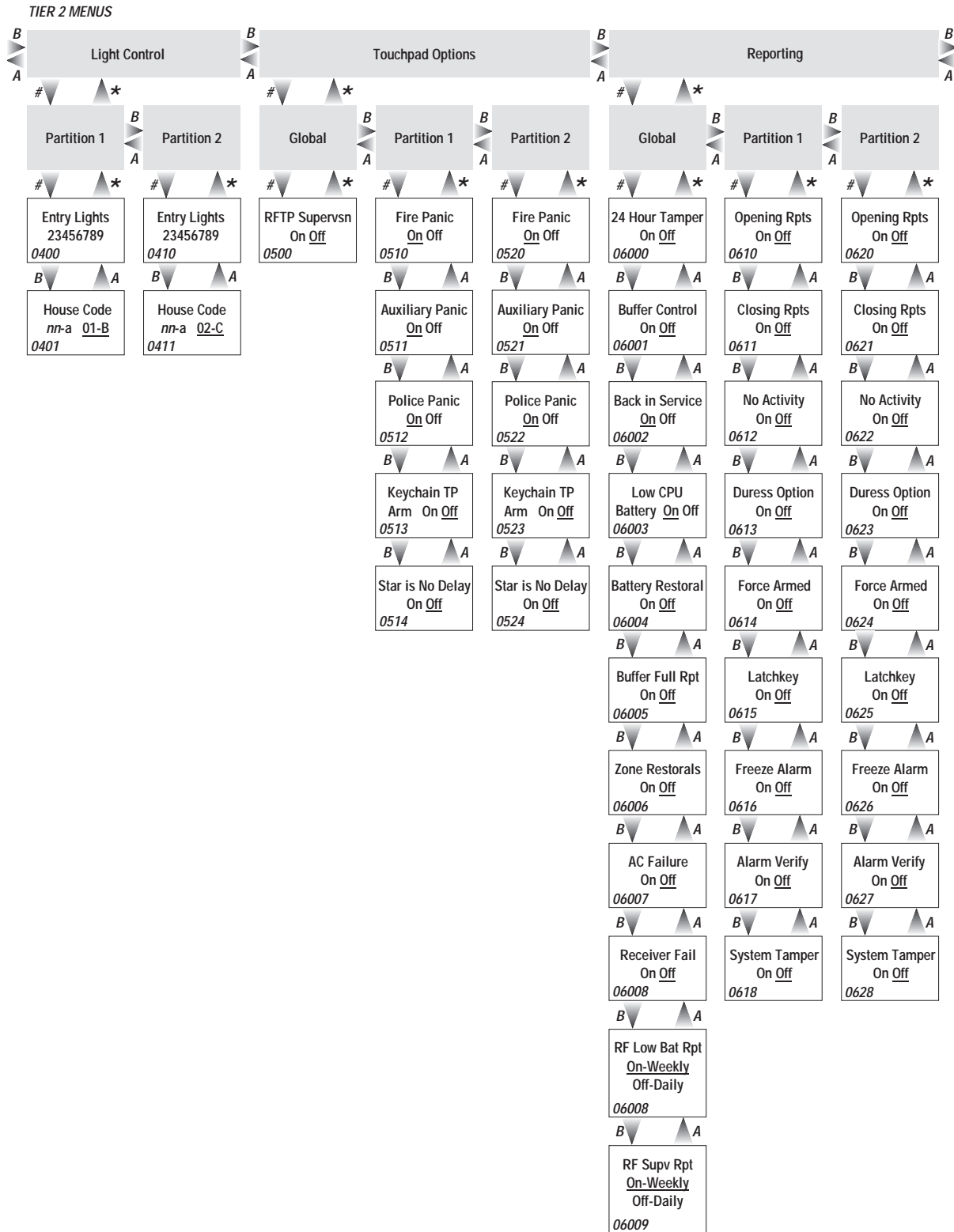

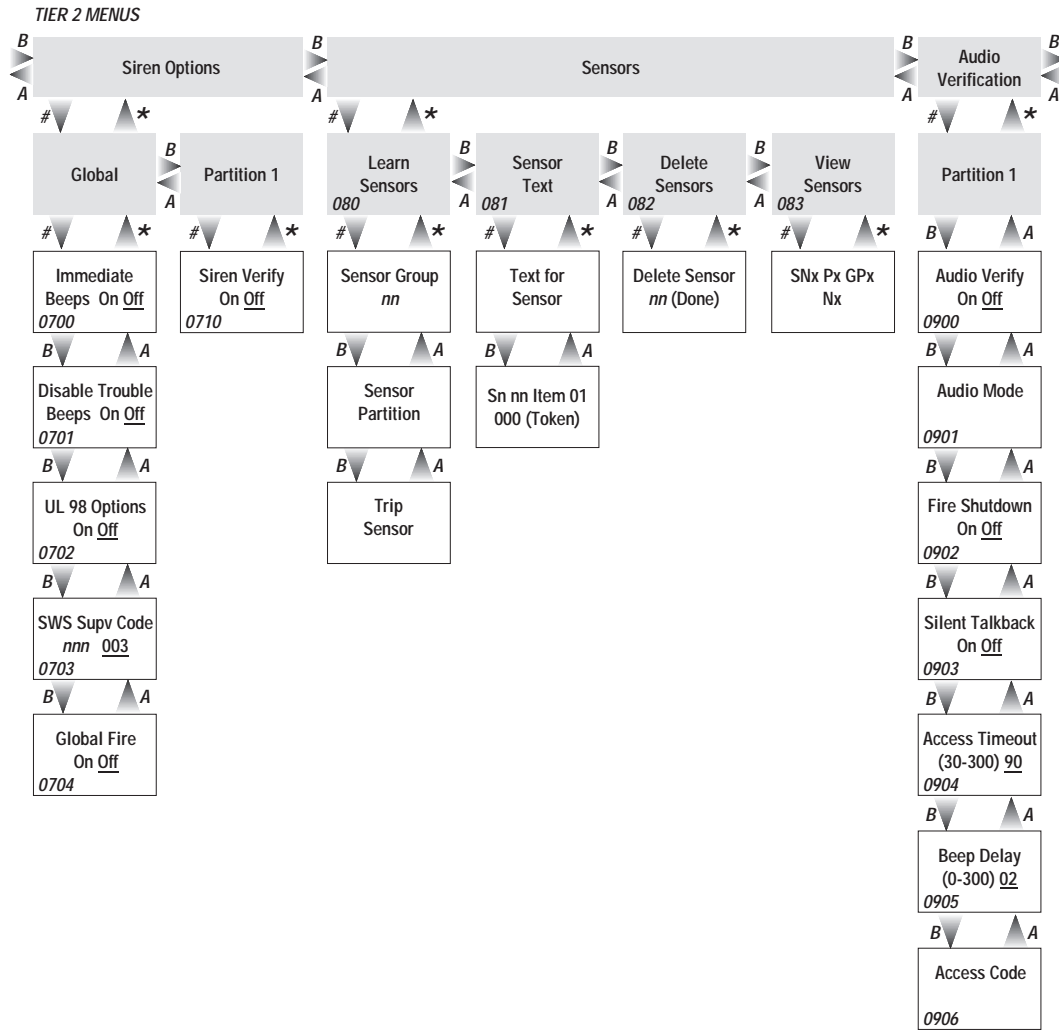

Using Menu Shortcuts

Concord allows you to get to the menu you want more quickly than pressing the **A**, **B**, and **#** buttons over and over.

1. Look at the programming flowchart included with this Student Guide and find the menu item you want to display.
2. Enter the number of the menu item you see on the programming flowchart.

For example: The Reporting Menu is **06**. When the system displays, “**SECURITY**”, press **06** to go directly to the Reporting Menu.

3. Almost all menu items on the programming flowchart have numbers. Use them to move directly to that choice.

Programming Shortcuts

Concord allows you to get to the menu you want more quickly than pressing the **A**, **B**, and **#** buttons over and over.

1. Look at the programming table and find the menu item you want to display. The programming functions are listed alphabetically.
2. Enter the number of the menu item you see on the programming flowchart.
3. For example: The Reporting Menu is **06**. When the system displays, “**SECURITY**”, press **06** to go directly to the Reporting Menu.
4. Almost all menu items on the programming flowchart have numbers. Use them to move directly to that choice.

System Programming	Shortcut Number	Available Settings	Defaults	Installer Setting
24-hour Tamper	05000	On/Off	Off	
AC Failure	05010	On/Off	Off	
Account Number Partition 1	0010	1-10 Digits Long		
Activity Timeout	0305	01-42 Hours	24 Hours	
Alarm Verify Partition 1	0516	On/Off	Off	
Auto Phone Test	02001	On/Off	Off	
Auto Stay Arming	0014	On/Off	On	
Auto Test Reset	02002	On/Off	On	
Back in Service	05002	On/Off	Off	
Backup Phone 1	0104	On/Off	On	
Backup Phone 2	0114	On/Off	On	
Battery Restoral	05005	On/Off	Off	
Buffer Control	05001	On/Off	Off	
Buffer Full Report	05006	On/Off	Off	
Bypass Reports	05003	On/Off	Off	
Call Wait Cancel	02009			
Cancel Message	02007	On/Off	On	

CONCORD
Programming

System Programming	Shortcut Number	Available Settings	Defaults	Installer Setting
Central Station Phone Number 1	0100	1-24 Digits Long	None	
Central Station Phone Number 2	0110	1-24 Digits Long	None	
Central Station Reporting Phone 1	0105	SIA/CID	CID	
Central Station Reporting Phone 2	0115	SIA/CID	CID	
Clear Memory				
Closing Reports Partition 1	0511	On/Off	Off	
Communication Failure	02003	On/Off	Off	
Daylight Saving Time	0306	On/Off	Off	
Dealer Code	0002	4-Digits	None	
Delete Sensors	072			
Demo Kit		On/Off	Off	
Dialer Abort	02005	On/Off	On	
Dialer Abort Delay	02006	15 - 20 Seconds	30 Seconds	
Disable Trouble Beeps	0601	On/Off	Off	
Downloader Code	0000	4-Digits	00000	
Downloader Phone Number	0150	1-24 Digits Long	None	
DTMF Dialing	02004	On/Off	On	
Duress Code Partition 1	0016	4-Digits	None	
Duress Report Partition 1	0514	On/Off	Off	
Edit Sensors	073			
Entry Delay Partition 1	0310	32-240 Seconds	32 Seconds	
Entry Lights Partition 1		Numbers 2-9	None	
Exit Delay Partition 1	0311	48-184 Seconds	64 Seconds	
Exit Extension	0013	On/Off	On	
Extended Delay Partition 1	0312	01-08 Minutes	04 Minutes	
High Level Reports Pager Phone 1	0121	On/Off	Off	
High Level Reports Pager Phone 2	0131	On/Off	Off	
High Level Reports Pager Phone 3	0141	On/Off	Off	
High Level Reports Phone 1	0101	On/Off	On	
High Level Reports Phone 2	0111	On/Off	Off	
Hourly Phone Test Partition 1		On/Off	Off	
Immediate Trouble Beeps	0600	On/Off	Off	
Installer Code	0001	4-Digits	4321	
Keychain TP Arm Partition 1	0403	On/Off	Off	
Keyswitch Arming		On/Off	Off	
Keyswitch Sensor	0015	Sensor # 01 - 14		
Latchkey Report Partition 1		On/Off	Off	
Latchkey Reports Pager Phone 1	0124	On/Off	On	
Latchkey Reports Pager Phone 2	0134	On/Off	On	
Latchkey Reports Pager Phone 3	0144	On/Off	On	

System Programming	Shortcut Number	Available Settings	Defaults	Installer Setting
Learn Sensors	070			
Low CPU Battery	05004	On/Off	Off	
Low Level Reports Pager Phone 1	0122	On/Off	Off	
Low Level Reports Pager Phone 2	0132	On/Off	Off	
Low Level Reports Pager Phone 3	0142	On/Off	Off	
Low Level Reports Phone 1	0102	On/Off	On	
Low Level Reports Phone 2	0112	On/Off	Off	
Manual Phone Test	02000	On/Off	On	
Next Phone Test	0303	001-255 Days	7 Days	
No Activity Report Partition 1	0513	On/Off	Off	
Open/Close Reports Pager Phone 1	0123	On/Off	Off	
Open/Close Reports Pager Phone 2	0133	On/Off	Off	
Open/Close Reports Pager Phone 3	0143	On/Off	Off	
Open/Close Reports Phone 1	0103	On/Off	Off	
Open/Close Reports Phone 2	0113	On/Off	Off	
Opening Report Partition 1	0510	On/Off	Off	
Output Trip Time	0304	1-12 Seconds	4 Seconds	
Pager Delay	02008	0-30 Seconds	15 Seconds	
Pager Phone Number 1	0120	1-24 Digits Long	None	
Pager Phone Number 2	0130	1-24 Digits Long	None	
Pager Phone Number 3	0140	1-24 Digits Long	None	
Phone Test Frequency	0302	1-255 Days	7 Days	
Quick Arm Partition 1	0011	On/Off	Off	
Quick Exit	0012	On/Off	On	
Receiver Failure	05011	On/Off	Off	
Recent Closings	0512	On/Off	On	
Remote Access Partition 1	0210	On/Off	On	
RF Check-in Time		02 -24 Hours	12 Hours	
RF Low Battery Report Weekly/Daily	05012	1 for Daily, 2 for Weekly	2	
RF Supervisory Reports Weekly/Daily	05013	1 for Daily, 2 for Weekly	2	
RF Touchpad Supervision		On/Off	Off	
Ring/Hang/Ring Partition 1	0211	On/Off	On	
Sensor Text	071			
Siren Timeout Partition 1	0313	1-30 Minutes	4 Minutes	
Siren Verify Partition 1	0610	On/Off	Off	
Smoke Verify	0900	On/Off	Off	
Star is No Delay Partition 1	0404	On/Off	Off	
Streamlining Pager Phone 1	0125	On/Off	On	
Streamlining Pager Phone 2	0135	On/Off	On	
Streamlining Pager Phone 3	0145	On/Off	On	

CONCORD
Programming

System Programming	Shortcut Number	Available Settings	Defaults	Installer Setting
Supervisory Time	0300	Enter Time of Day	00:00	
System Tamper Partition 1	0517	On/Off	Off	
TP Auxiliary Panic Partition 1	0401	On/Off	On	
TP Fire Panic Partition 1	0400	On/Off	On	
TP Panic Report Format	0401	On/Off	Off	
TP Police Panic Partition 1	0402	On/Off	On	
Two Trip Error	05008	On/Off	Off	
Two Wire Smoke Loop	0901	On/Off	Off	
UL 98 Options	0602	On/Off	Off	
Zone Restoral Report	05007	On/Off	Off	

Programming Defaults and Definitions

24-HOUR TAMPER (05000)

DEFAULT = OFF

This setting determines whether the panel sounds sirens and reports a tamper alarm when wireless sensor tamper switches are activated, even when the system is disarmed (OFF).

NOTE

For U.L. Commercial Listed installations, this feature must be on.

Turning On or Off

With the display showing *24-HOUR TAMPER OFF/ON (current setting)*, press **1** (off) or **2** (on), then press #.

The display flashes the entered setting, then stops after pressing # and displays *24-HOUR TAMPER OFF/ON (new setting)*.

ACCESS CODE (0906)

DEFAULT = NONE

This setting determines the code required to access the Interrogator 200 to start an audio session. If no code is programmed, pressing **ⓧ** starts an audio session.

Programming

With the display showing *AUDIO VERIFICATION OFF/ON*, press **B** until the display shows *ACCESS CODE nnnn (current code)*.

Enter the desired 4-digit access code, then press #. The display flashes the entered code, then stops after pressing # and displays *ACCESS CODE nnnn (new code)*.

ACCESS TIMEOUT (0904)

DEFAULT = 90 SECONDS

This setting determines how much time (30 - 300 seconds, in 2-second increments) the central station operator has to enter the AVM access code, after the panel is accessed for an audio session (instant mode only).

Programming

With the display showing *AUDIO VERIFICATION OFF/ON*, press **B** until the display shows *ACCESS TIMEOUT nn SECS (current setting)*.

Enter the desired time, then press #.

The display flashes the entered setting, then stops after pressing # and displays *ACCESS TIMEOUT nn SECS (new setting)*.

AC FAILURE (05010)

DEFAULT = OFF

This setting determines whether the panel reports to the central station after AC power to the panel is out for 15 minutes.

Turning On or Off

With the display showing *AC FAILURE OFF/ON (current setting)*, press **1** (off) or **2** (on), then press #.

The display flashes the entered setting, then stops after pressing # and displays *AC FAILURE OFF/ON (new setting)*.

ACCOUNT NUMBER (0010—PARTITION 1, 0020—PARTITION 2)

DEFAULT = 00000

The account number is used as panel (or customer) identification for the central monitoring station. The panel sends the account number every time it reports to the central station. Account numbers must be 1 to 10 digits long.

Programming

With the desired partition selected, press **B** until the display shows *ACCOUNT NUMBER nnnnn*.

Enter the desired account number, then press #.

The display flashes the entered number, then stops after pressing # and displays *ACCOUNT NUMBER nnnnn (new account number)*.

CONCORD
Programming

ACTIVITY TIMEOUT (0305)

DEFAULT = 24 HOURS

This setting determines how long the system goes (01 - 42 hours) without user interaction and device activation before sending a 'no activity' report to the central station.

Programming

With the display showing *ENTER ACTIVITY TIMEOUT nn HOURS (current setting)* enter the desired 2-digit time value (01 - 42), then press #.

The display flashes the entered setting, then stops after pressing # and displays *ACTIVITY TIMEOUT nn HOURS (new setting)*.

ALARM VERIFY (0516—PARTITION 1, 0526—PARTITION 2)

DEFAULT = OFF

This setting determines whether the panel goes into alarm and reports after a single sensor/zone trip (off) or waits for a second trip signal (on).

NOTE

This setting applies only to sensors/zones learned into groups 10 - 20. If Alarm Verify is set to on, group 18 responds the same as group 17.

Turning On or Off

With the desired partition selected, press **B** until the display shows *ALARM VERIFY OFF/ON (current setting)*.

Press **1** (off) or **2** (on), then press #.

The display flashes the entered setting, then stops after pressing # and displays *ALARM VERIFY OFF/ON (new setting)*.

AUDIO MODE (0901)

DEFAULT = 01

This setting determines how the Interrogator 200 operates. Choose one of the following:

(01) Instant—Allows the central station operator instant access for an audio session by entering the AVM code or by pressing **ⓧ** (if an AVM access code is not programmed), upon completion of panel alarm report.

(02) Callback—allows the central station operator to contact persons on the premises after one ring and verify the alarm report. Operator must press **ⓧ** or enter the AVM access code within 20 seconds after ring. The panel does not report any alarms during the AVM session, except for fire alarms.

(03) Callback Silent—same as Callback except premises phones do not ring.

Programming

With the display showing *AUDIO VERIFICATION OFF/ON*, press **B** until the display shows *AUDIO MODE nn (current setting)*.

Enter the desired mode number (01 - 03), then press #.

The display flashes the entered setting, then stops after pressing # and displays *AUDIO MODE nn (new setting)*.

AUDIO VERIFICATION (0900)

DEFAULT = OFF

This setting determines whether the system can be accessed by phone for alarm verification, using an Interrogator 200.

NOTE

Audio Verification has not been verified by U.L.

Turning On or Off

With the display showing *AUDIO VERIFICATION*, press #. The display shows *PARTITION 1*.

Press # again and the display shows *AUDIO VERIFY OFF/ON (current setting)*.

Press **1** (off) or **2** (on), then press #.

The display flashes the entered setting, then stops after pressing # and displays *AUDIO VERIFY OFF/ON (new setting)*.

AUTO PHONE TEST (02001)

DEFAULT = OFF

This setting determines if the panel sends a phone test automatically to the central station or a pager on a predetermined schedule. (Refer to the “Phone Test Freq.” and “Next Phone Test” settings found under *TIMERS—GLOBAL*).

Turning On or Off

With the display showing *AUTO PHONE TEST OFF/ON (current setting)*, press 1 (off) or 2 (on), then press #.

The display flashes the entered setting, then stops after pressing # and displays *AUTO PHONE TEST OFF/ON (new setting)*.

AUXILIARY PANIC (0511—PARTITION 1, 0521—PARTITION 2)

DEFAULT = ON

This setting determines whether the auxiliary panic buttons are enabled (on) or disabled (off) on touchpads for a selected partition.

Programming

With the desired partition selected, press **B** until the display shows *AUXILIARY PANIC OFF/ON (current setting)*.

Press 1 (off) or 2 (on), then press #. The display flashes the entered setting, then stops after pressing # and displays

AUXILIARY PANIC OFF/ON (new setting).

BACK IN SERVICE (05002)

DEFAULT = ON

This setting determines whether the panel reports to the central station after AC and backup battery power are restored after an extended power outage.

Turning On or Off

With the display showing *BACK IN SERVICE OFF/ON (current setting)*, press 1 (off) or 2 (on), then press #.

The display flashes the entered setting, then stops after pressing # and displays *BACK IN SERVICE OFF/ON (new setting)*.

BACKUP (0105-CS PHONE 1, 0115-CS PHONE 2, 0125-CS PHONE 3)

**DEFAULTS: CS PHONE 1 = ON,
CS PHONE 2 = OFF
CS PHONE 3 = OFF**

This setting determines whether the panel uses another programmed central station phone number for reporting if three initial attempts are unsuccessful. CS PHONE 1 is backed up by CS PHONE 2, and CS PHONE 2 and 3 are backed up by CS PHONE 1. The panel makes up to 16 attempts (8 per phone number), alternating between the two programmed phone numbers.

For example, if *BACKUP* is on and three failed reporting attempts occur using CS PHONE 1, the panel switches to CS PHONE 2 for three more reporting attempts. If these attempts fail, the panel switches back to CS PHONE 1 for five more reporting attempts and, if necessary, switches back to CS PHONE 2 for five final attempts.

Turning On or Off

With the display showing *BACKUP OFF/ON (current setting)*, press 1 (off) or 2 (on), then press #.

The display flashes the entered setting, then stops after pressing # and displays *BACKUP OFF/ON (new setting)*.

BATTERY RESTORAL (05005)

DEFAULT = OFF

This setting determines whether the panel reports to the central monitoring station or pager, when a wireless sensor reports to the panel after battery replacement.

Turning On or Off

With the display showing *BATTERY RESTORAL OFF/ON (current setting)*, press 1 (off) or 2 (on), then press #.

The display flashes the entered setting, then stops after pressing # and displays *BATTERY RESTORAL OFF/ON (new setting)*.

CONCORD
Programming

BEEP DELAY (0905)

DEFAULT = 02 SECONDS

This setting determines how long AVM access beeps are delayed (0 - 300 seconds, in 2-second intervals) at the beginning of a 2-way audio session.

Programming

With the display showing *AUDIO VERIFICATION OFF/ON*, press **B** until the display shows *BEEP DELAY nn SECS (current setting)*.

Enter the desired time, then press #.

The display flashes the entered setting, then stops after pressing # and displays *BEEP DELAY nn SECS (new setting)*.

BUFFER CONTROL (05001)

DEFAULT = OFF

This setting determines whether all system events are logged in the buffer (off) or if only opening and closing reports are logged in the buffer (on).

Turning On or Off

With the display showing *BUFFER CONTROL OFF/ON (current setting)*, press **1** (off) or **2** (on), then press #.

The display flashes the entered setting, then stops after pressing # and displays *BUFFER CONTROL OFF/ON (new setting)*.

BUFFER FULL REPORT (05006)

DEFAULT = OFF

This setting determines whether the panel sends an event buffer full report to the central monitoring station when the event buffer is nearly full.

Turning On or Off

With the display showing *BUFFER FULL RPT OFF/ON (current setting)*, press #.

Press **1** (off) or **2** (on), then press #.

The display flashes the entered setting, then stops after pressing # and displays *BUFFER FULL RPT OFF/ON (new setting)*.

CLOSING REPORTS (0511—PARTITION 1, 0521—PARTITION 2)

DEFAULT = OFF

This setting determines whether the panel sends a closing report to the central station or pager, after the partition is armed.

Turning On or Off

With the desired partition selected, press **B** until the display shows *CLOSING REPORTS OFF/ON (current setting)*.

Press **1** (off) or **2** (on), then press #.

The display flashes the entered setting, then stops after pressing # and displays *CLOSING REPORTS OFF/ON (new setting)*.

COMMUNICATION FAILURE (0202)

DEFAULT = ON

This setting determines whether the panel activates trouble beeps to alert users on the premises that communication to the central station failed. Failure notification occurs after the third unsuccessful reporting attempt to the central station/pager.

If a Phone Supervision Card (60-789) is installed, failure notification can occur immediately if inadequate phone line voltage is detected upon the initial dialing attempt.

NOTE

For UL Listed installations, Communication Failure must be turned on.

Turning On or Off

With the display showing *COMM FAILURE OFF/ON (current setting)*, press **1** (off) or **2** (on), then press #.

The display flashes the entered setting, then stops after pressing # and displays *COMM FAILURE OFF/ON (new setting)*.

DAYLIGHT SAVINGS (0306)

DEFAULT = ON

This setting determines whether the panel's clock automatically adjusts for daylight savings time changes in spring and fall.

Turning On or Off

With the display showing *DAYLIGHT SAVINGS OFF/ON (current setting)*, press **1** (off) or **2** (on), then press #.

The display flashes the entered setting, then stops after pressing # and displays *DAYLIGHT SAVINGS OFF/ON (new setting)*.

DEALER CODE (0002)

DEFAULT = NONE

The 4-digit dealer code is used to prevent unauthorized persons from changing the programmed central station phone number. When changed from its default setting, all central station phone numbers can be changed only by entering program mode using the dealer code. (If a Dealer Code is programmed, entering program mode with the installer code lets you program all system settings except for the Dealer Code and central station phone numbers.)

Programming

With the display showing *DEALER CODE *****, enter the desired **4-digit code + #**.

The display flashes the entered code, then stops after pressing # and displays *DEALER CODE nnnn (new code)*.

Deleting

With the display showing *DEALER CODE nnnn (current code)*, press **D**.

The display shows *DEALER CODE *****.

NOTE

The Dealer Code cannot be deleted by clearing panel memory. If you don't remember your Dealer Code, call Technical Services for assistance.

DELETE SENSORS (082)

DEFAULT = NONE

The following describes how to remove hardwire zone and wireless sensor numbers from panel memory.

NOTE

Deleting sensors does not delete sensor text associated with the deleted sensor number. To delete sensor text, enter the SENSOR TEXT menu and enter 000 (nulls) for each item number.

Programming

To Delete Sensors from panel memory:

- With the display showing *LEARN SENSORS*, press **B** until the display shows *DELETE SENSORS*.
- Press # and the display shows *DELETE SN NN (lowest zone/sensor number in panel memory)*.
- Press # to delete the displayed sensor or enter the desired sensor number, then press #.
The display flashes the entered number, then stops and shows *DELETE SENSOR NN DONE*.

Repeat steps 2 and 3 until all desired sensors are deleted.

DELETE TOUCHPAD (1201—PARTITION 1, 1211—PARTITION 2)

DEFAULT = NONE

This menu lets you delete wireless touchpads from panel memory.

Programming

- With the display showing *WIRELESS TOUCHPADS*, press #. The display shows *PARTITION 1*.
- Press **A** or **B** to select the desired partition, then press #. The display shows *LEARN TOUCHPAD*.
- Press **B** and the display shows *DELETE TOUCHPAD*.
- Press # and the display shows *DELETE TOUCHPAD 01*.
- Press **A** or **B** to select 01, 02, 03, or 04, then press #. The display shows *DELETE TOUCHPAD nn DONE*.

DIALER ABORT (0204)

DEFAULT = ON

This setting determines whether users can stop the panel from reporting an intrusion or auxiliary alarm condition to the central station. If dialer abort is on and the user accidentally causes an alarm condition, entering **1 + CODE** within 30 seconds stops the panel from reporting the alarm, preventing a false dispatch. Fire alarm reports to the central station cannot be aborted.

NOTE

The Dialer Abort feature applies only to CS PHONE 1. The 30-second time setting can only be changed using ITI ToolBox.

Turning On or Off

With the display showing *DIALER ABORT OFF/ON (current setting)*, press **1** (off) or **2** (on), then press #.

The display flashes the entered setting, then stops after pressing # and displays *DIALER ABORT OFF/ON (new setting)*.

CONCORD Programming

DISABLE TROUBLE BEEPS (0701)

DEFAULT = OFF

This setting determines whether the panel activates trouble beeps when a wireless sensor supervisory condition is detected.

NOTE

For UL Listed installations, this feature must be off.

Turning On or Off

With the display showing *DISABLE TR BEEPS OFF/ON (current setting)*, press 1 (off) or 2 (on), then press #.

The display flashes the entered setting, then stops after pressing # and displays *DISABLE TR BEEPS OFF/ON (new setting)*.

DOWNLOADER CODE (0000)

DEFAULT = 12345

The 5-digit downloader code is used in conjunction with downloader programming. The downloader operator must have the panel account number and downloader code to perform any programming.

Programming

With the display showing *DOWNLOADER CODE nnnnn (current code)*, enter the desired 5-digit code, + #.

The display flashes the entered code, then stops after pressing # and displays *DOWNLOADER CODE nnnnn (new code)*.

NOTE

The Downloader Code cannot be deleted or cleared from panel memory. To change the Downloader Code to its default setting, enter 12345 in the procedure above.

DTMF DIALING (0203)

DEFAULT = ON

This setting determines whether the panel uses DTMF tones (on) or pulse (off) for dialing programmed phone numbers.

Turning On or Off

With the display showing *DTMF DIALING OFF/ON (current setting)*, press 1 (off) or 2 (on), then press #.

The display flashes the entered setting, then stops after pressing # and displays *DTMF DIALING OFF/ON (new setting)*.

DURESS CODE (0013—PARTITION 1, 0023—PARTITION 2)

DEFAULT = NONE

The duress code is a unique 4-digit access code that allows users to operate the system and, at the same time, instructs the panel to send a silent alarm report to the central station. Each partition can be programmed with a different duress code.

CAUTION

Because using duress codes often results in false alarms due to code entry errors, it is strongly recommended not to program duress codes. If a duress code is absolutely necessary, their use with an Interrogator 200 is highly recommended to reduce false alarms and accidental dispatches.

Programming

With the desired partition selected, press **B** until the display shows *DURESS CODE *****.

Enter the desired 4-digit duress code, then press #.

The display flashes the entered setting, then stops after pressing # and displays *DURESS CODE nnnn (new code)*.

With the desired partition selected, press **B** until the display shows *DURESS CODE nnnn (current code)*.

DURESS OPTION (0613—PARTITION 1, 0623—PARTITION 2)

DEFAULT = OFF

This setting determines whether the selected partition can be controlled using a programmed duress code (see *SECURITY—PARTITION ½—DURESS CODE*).

CAUTION

Because user-code entry errors often result in false alarms, it is strongly recommended not to program any duress codes. If a duress code is absolutely necessary, their use with an Interrogator 200 is highly recommended to reduce false alarms and accidental dispatches.

Turning On or Off

With the desired partition selected, press **B** until the display shows *DURESS OPTION OFF/ON (current setting)*.

Press 1 (off) or 2 (on), then press #.

The display flashes the entered setting, then stops after pressing # and displays *DURESS OPTION OFF/ON (new setting)*.

ENTRY DELAY (0310—PARTITION 1, 0320—PARTITION 2)

DEFAULT = 032 SECONDS

This setting determines how much time (32 - 240 seconds) the user has to disarm the system after entering the premises through a designated delay door, to avoid causing an alarm.

NOTE

For UL Listed residential installations, the Entry Delay must be set to 45 seconds.

Programming

With the desired partition selected, press **B** until the display shows *ENTRY DELAY nnn SECONDS (current setting)*.

Enter the desired time value, then press #.

The display flashes the entered setting, then stops after pressing # and displays *ENTRY DELAY nnn SECONDS (new setting)*.

ENTRY LIGHTS (0400—PARTITION 1, 0410—PARTITION 2)

DEFAULT = NONE

This setting determines whether X-10 controlled lights set to numbers 2 - 9 turn on during entry and exit delays.

NOTE

X-10 Lamp Modules set to 1 always turn on during the entry and exit delays. X-10 Lamp Modules set to 2 always flash the arming level when arming the system. For example, lights flash two times when arming to STAY (level 2); three times when arming to AWAY (level 3).

NOTE

Lamp Modules set to 2 should not be set up as entry lights, since this setting flashes the arming level immediately after arming.

Programming

With the desired partition selected, press **B** until the display shows *ENTRY LIGHTS nnnnnnnn (current setting)*.

Enter the desired light numbers (2 - 9 based on the UNIT dial setting on each X-10 Lamp Module), then press #.

The display shows *ENTRY LIGHTS nnnnnnnn (new setting)*.

Deleting

Enter any light number that appears on the display, then press #. The number disappears from the display.

EXCEPTION REPORTS (0133-PAGER 1, 0143-PAGER 2, 0153-PAGER 3, 0163-PAGER 4, 0173-PAGER 5)

DEFAULT = OFF

This setting determines whether the panel reports to a pager if the system is not armed or disarmed at the specified schedule times, if open/close reports are turned on.

Turning On or Off

With the display showing *EXCEPTION RPTS OFF/ON (current setting)*, press **1** (off) or **2** (on), then press #.

The display flashes the entered setting, then stops after pressing # and displays *EXCEPTION RPTS OFF/ON (new setting)*.

EXCEPTION REPORTS (0103-CS PHONE 1, 0113-CS PHONE 2, 0123-CS PHONE 3)

DEFAULTS: ALL OFF

This setting determines whether the panel reports to the central station if the system is not armed or disarmed at the specified schedule times, if open/close reports are turned on.

Turning On or Off

With the display showing *EXCEPTION RPTS OFF/ON (current setting)*, press **1** (off) or **2** (on), then press #.

The display flashes the entered setting, then stops after pressing # and displays *EXCEPTION RPTS OFF/ON (new setting)*.

EXIT DELAY (0311—PARTITION 1, 0321—PARTITION 2)

DEFAULT = 064 SECONDS

This setting determines how much time (48 - 184 seconds) the user has to leave the premises through a designated delay door after arming the system, to avoid causing an alarm.

NOTE

For UL Listed residential installations, the Exit Delay must be set to 60 seconds.

Programming

With the desired partition selected, press **B** until the display shows *EXIT DELAY nnn SECONDS (current setting)*.

Enter the desired time value, then press #.

The display flashes the entered setting, then stops after pressing # and displays *EXIT DELAY nnn SECONDS (new setting)*.

CONCORD
Programming

EXTENDED DELAY (0312—PARTITION 1, 0322—PARTITION 2)

DEFAULT = 04 MINUTES

This setting determines how much time (01 - 08 minutes) the user has to enter or exit the premises through a designated extended delay door, without causing an alarm.

Programming

With the desired partition selected, press **B** until the display shows *EXTENDED DELAY nn MINUTES (current setting)*.

Enter the desired time value, then press #.

The display flashes the entered setting, then stops after pressing # and displays *EXTENDED DELAY nn MINUTES (new setting)*.

FIRE PANIC (0510—PARTITION 1, 0520—PARTITION 2)

DEFAULT = ON

This setting determines whether the fire panic buttons are enabled (on) or disabled (off) on touchpads for a selected partition.

Programming

With the desired partition selected, press **B** until the display shows *FIRE PANIC OFF/ON (current setting)*.

Press **1** (off) or **2** (on), then press #. The display flashes the entered setting, then stops after pressing # and displays *FIRE PANIC OFF/ON (new setting)*.

FIRE SHUTDOWN (0902)

DEFAULT = OFF

This setting determines whether system sirens turn off during a fire alarm audio session.

Turning On or Off

With the display showing *AUDIO VERIFICATION OFF/ON*, press **B** until the display shows *FIRE SHUTDOWN OFF/ON (current setting)*.

Press **1** (off) or **2** (on), then press #.

The display flashes the entered setting, then stops after pressing # and displays *FIRE SHUTDOWN OFF/ON (new setting)*.

FORCE ARMED (0614—PARTITION 1, 0624—PARTITION 2)

DEFAULT = OFF

This setting determines whether the panel reports to the central monitoring station when a sensor/zone is bypassed, directly or indirectly.

NOTE

Auto Force Armed (when the panel arms itself) always reports to the central monitoring station. For UL Listed installations, Force Armed must be turned off.

Turning On or Off

With the desired partition selected, press **B** until the display shows *FORCE ARMED OFF/ON (current setting)*.

Press **1** (off) or **2** (on), then press #.

The display flashes the entered setting, then stops after pressing # and displays *FORCE ARMED OFF/ON (new setting)*.

FREEZE ALARM (0616—PARTITION 1, 0626—PARTITION 2)

DEFAULT = OFF

This setting determines whether the panel reports a freeze alarm to the central station or pager, when the selected partition's energy saver module detects a temperature that matches a predetermined setting (see *BUS DEVICES—UNIT TYPE nn ESM—PARTITION 1/2—FREEZE TEMP*).

Turning On or Off

With the desired partition selected, press **B** until the display shows *FREEZE ALARM OFF/ON (current setting)*.

Press **1** (off) or **2** (on), then press #.

The display flashes the entered setting, then stops after pressing # and displays *FREEZE ALARM OFF/ON (new setting)*.

GLOBAL FIRE (0704)

DEFAULT = OFF

This setting determines whether sirens in both partitions sound (on) if either partition activates a fire alarm.

Turning On or Off

With the display showing *GLOBAL FIRE OFF/ON (current setting)*, press 1 (off) or 2 (on), then press #.

The display flashes the entered setting, then stops after pressing # and displays *GLOBAL FIRE OFF/ON (new setting)*.

HANG/RING (0211—PARTITION 1, 0221—PARTITION 2)

DEFAULT = ON

This setting determines how the panel picks up (seizes) the phone line for remote access. When turned on, the user calls the premises, listens for one or two full rings, hangs up, then calls the premises again within 10-40 seconds of hanging up. The system answers after the first ring. The “on” setting is recommended if an answering machine shares the phone line with the panel.

When turned off, the user calls the premises and listens for 12 full rings before the system answers. The “off” setting is recommended if there is no answering machine sharing the phone line with the panel.

Turning On or Off

With the desired partition selected, press B until the display shows *RING/HANG/RING OFF/ON (current setting)*.

Press 1 (off) or 2 (on), then press #.

The display begins flashing the entered selection, then stops and displays *RING/HANG/RING OFF/ON (new setting)*.

HIGH LEVEL REPORTS (0131-PAGER 1, 0141-PAGER 2, 0151-PAGER 3, 0161-PAGER 4, 0171-PAGER 5)

DEFAULT = ON

This setting determines whether the following alarm conditions report to a pager:

Fire, Police, Auxiliary, Duress, and Freeze alarms, No Activity, Receiver Failure (or jam), and System Tamper (40 incorrect key presses or touchpad supervisory).

Turning On or Off

With the display showing *HIGH LEVEL RPTS OFF/ON (current setting)*, press 1 (off) or 2 (on), then press #.

The display flashes the entered setting, then stops after pressing # and displays *HIGH LEVEL RPTS OFF/ON (new setting)*.

HIGH LEVEL REPORTS (0101-CS PHONE 1, 0111-CS PHONE 2, 0121-CS PHONE 3)

**DEFAULTS: CS PHONE 1 = ON
CS PHONE 2 = OFF
CS PHONE 3 = OFF**

This setting determines whether the following conditions report to the central station:

Fire, Police, Auxiliary, Duress, and Freeze alarms, No Activity, Receiver Failure (or jam), and System Tamper (40 incorrect key presses or touchpad supervisory).

Turning On or Off

With the display showing *HIGH LEVEL RPTS OFF/ON (current setting)*, press 1 (off) or 2 (on), then press #.

The display flashes the entered setting, then stops after pressing # and displays *HIGH LEVEL RPTS OFF/ON (new setting)*.

HOURLY LINE TEST (0212—PARTITION 1 ONLY)

DEFAULT = OFF

This setting determines whether the panel checks the phone line voltage every hour.

NOTE

The panel must have a Phone Supervision Card (60-789) installed for this feature to work.

Turning On or Off

With partition 1 selected, press B until the display shows *HOURLY LINE TEST OFF/ON (current setting)*.

Press 1 (off) or 2 (on), then press #.

The display flashes the entered setting, then stops after pressing # and displays *HOURLY LINE TEST OFF/ON (new setting)*.

CONCORD
Programming

HOUSE CODE (0401—PARTITION 1, 0411—PARTITION 2)

**DEFAULTS: PARTITION 1 = 01-B
PARTITION 2 = 02-C**

This setting determines which Supervised Wireless Sirens and X-10 controlled lights work in a selected partition. The letter that appears after the house code number indicates the necessary HOUSE dial setting for X-10 modules in that partition.

NOTE

You must set the partition House Code and the SWS Supv Code (see the *SIREN OPTIONS* menu) *before* plugging in Supervised Wireless Sirens.

Programming

With the desired partition selected, press **B** until the display shows *HOUSE CODE nn-x (current setting)*.

Enter the desired number (1 - 255), then press #.

The display flashes the entered setting, then stops after pressing # and displays *HOUSE CODE nn-x (new setting)*.

IMMEDIATE BEEPS (0700)

DEFAULT = OFF

This setting determines when the panel activates trouble beeps, once a wireless sensor supervisory condition is detected. When set to off, trouble beeps sound within 4 hours for fire (group 26) sensors and within 10 hours for all other sensors.

NOTE

For UL Listed installations, this feature must be on.

Turning On or Off

With the display showing *IMMEDIATE BEEPS OFF/ON (current setting)*, press **1** (off) or **2** (on), then press #.

The display flashes the entered setting, then stops after pressing # and displays *IMMEDIATE BEEPS OFF/ON (new setting)*.

INSTALLER CODE (0001)

DEFAULT = 4321

The 4-digit installer code is used for entering program mode and changing system settings. If a dealer code (see below) is programmed, only those settings not associated with phone numbers can be changed.

Programming

With the display showing *INSTALLER CODE nnnn (current code)*, enter the desired **4-digit code + #**.

The display flashes the entered code, then stops after pressing # and displays *INSTALLER CODE nnnn (new code)*.

NOTE

The Installer Code cannot be deleted or cleared from panel memory. To change the Installer Code to its default setting, enter 4321 in the procedure above.

KEYCHAIN ARMING (0513—PARTITION 1, 0523—PARTITION 2)

DEFAULT = OFF

This setting determines whether keychain touchpads arm the selected partition directly to AWAY with NO DELAY (on) or increments from OFF to STAY, or from STAY to AWAY (off).

Programming

With the desired partition selected, press **B** until the display shows *KEYCHAIN TOUCHPAD ARM OFF/ON (current setting)*.

Press **1** (off) or **2** (on), then press #. The display flashes the entered setting, then stops after pressing # and displays

KEYCHAIN TOUCHPAD ARM OFF/ON (new setting).

KEYSWITCH ARMING (0012—PARTITION 1, 0022—PARTITION 2)

DEFAULT = OFF

Keyswitch arming allows partition 1 arming using a wired keyswitch connected to a hardwire zone (loop) input or a wireless door/window sensor, learned as zone/sensor number 01.

Turning On or Off

With partition 1 selected, press **B** until the display shows *KEYSWITCH ARMING OFF/ON (current setting)*.

Press **1** (off) or **2** (on), then press #.

The display flashes the entered setting, then stops after pressing # and displays *KEYSWITCH ARMING OFF/ON (new setting)*.

LATCHKEY FORMAT (0615—PARTITION 1, 0625—PARTITION 2)

DEFAULT = OFF

This setting determines whether the selected partition is set up for basic (off) or advanced (on) latchkey opening report operation.

Programming

Basic

- a). If the partition is armed by entering 2 (or 3) + CODE, *disarming using a designated latchkey user code within an assigned time schedule* sends a page.
- b). If the partition is armed by entering 2 (or 3) + CODE + 6 (LATCHKEY), *disarming using a designated latchkey user code inside or outside of an assigned time schedule* sends a page.

Advanced

If the partition is armed by entering 2 (or 3) + CODE + 6 (LATCHKEY), *disarming using a latchkey designated user code within an assigned time schedule* sends a page.

Refer to the *User's Guide* for complete Latchkey setup and operation.

Turning On or Off

With the desired partition selected, press **B** until the display shows *LATCHKEY FORMAT OFF/ON (current setting)*.

Press **1** (off—basic) or **2** (on—advanced), then press **#**.

The display flashes the entered setting, then stops after pressing **#** and displays *LATCHKEY FORMAT OFF/ON (new setting)*.

LATCHKEY REPORTS (0135-PAGER 1, 0145-PAGER 2, 0155-PAGER 3, 0165-PAGER 4, 0175-PAGER 5)

DEFAULT = ON

This setting determines whether the panel reports to a pager when the system is armed or disarmed, according to latchkey time scheduling.

Turning On or Off

With the display showing *LATCHKEY REPORTS OFF/ON (current setting)*, press **1** (off) or **2** (on), then press **#**.

The display flashes the entered setting, then stops after pressing **#** and displays *LATCHKEY REPORTS OFF/ON (new setting)*.

LEARN TOUCHPAD (1200—PARTITION 1, 1210—PARTITION 2)

DEFAULT = NONE

This menu lets you learn wireless touchpads into panel memory.

Programming

- With the display showing *WIRELESS TOUCHPADS*, press **#**. The display shows *PARTITION 1*.
- Press **A** or **B** to select the desired partition, then press **#**. The display shows *LEARN TOUCHPAD*.
- Press **#** and the display shows *TRIP TOUCHPAD nn*, where *nn* is the lowest available touchpad number 01 - 04.
- Press **A** or **B** to select 01, 02, 03, or 04, then press **#**.
- Press the **BYPASS** button on wall-mount and handheld touchpads or the **LOCK** and **UNLOCK** buttons together on keychain touchpads. The display shows *TRIP TOUCHPAD nn*, where *nn* is the next available touchpad number.
- Repeat step 3 until all touchpads are learned.

Deleting

Press **D**. The display shows *DURESS CODE *****.

LEARN SENSORS (080)

DEFAULT = NONE

The following describes how to learn hardwire zones and wireless sensors into panel memory.

Programming

- With the display showing *SENSORS*, press # and the display shows *LEARN SENSORS*.
- Press # and the display shows *SENSOR PTN 1*.
- Press # to select partition 1 or press 2 + # to select partition 2. The display should show *SENSOR GROUP 00*. Enter the desired 2-digit sensor group + # (see Table A.5 in "Appendix A" for a description of all sensor group characteristics). The display shows *TRIP SENSOR nn*, where nn is the displayed (next available) sensor number.
- To change the displayed sensor number, enter the desired 2-digit sensor number, then press #.
- With the desired sensor number displayed, trip the sensor or zone as follows: **Hardwire Zones**—trip the zone into the alarm state.
- **Wireless Sensors**—follow the instructions included with each sensor.
Wireless Door/Window Sensors with External Contacts—place the external contact in the alarm condition, then activate the sensor's tamper switch.
- **Supervised Wireless Sirens**—connect the siren battery then plug the siren into an electrical outlet.

NOTE

Before learning Supervised Wireless Sirens, you must first program a partition house code (see *LIGHT CONTROL* menu) and the SWS house code (see *SIREN OPTIONS* menu).

- Continue tripping sensors to learn them into the selected sensor group and partition. To stop learning sensors into this group and partition, press * twice and start again from step 2 (*LEARN SENSORS*) to learn sensors into another group and partition.

LOW CPU BATTERY (06003)

DEFAULT = ON

This setting determines whether the panel reports a low panel battery to the central station or pager, before shutting down.

Turning On or Off

With the display showing *LOW CPU BATTERY OFF/ON (current setting)*, press 1 (off) or 2 (on), then press #.

The display flashes the entered setting, then stops after pressing # and displays *LOW CPU BATTERY OFF/ON (new setting)*.

LOW LEVEL REPORTS (0132-PAGER 1, 0142-PAGER 2, 0152-PAGER 3, 0162-PAGER 4, 0172-PAGER 5)

DEFAULT = OFF

This setting determines whether the following non-alarm conditions report to a pager:

Force Armed, Hardwire Zone Trouble (open or short), Supervisory (wireless sensors), Low Battery (wireless sensors and touchpads).

Turning On or Off

With the display showing *LOW LEVEL RPTS OFF/ON (current setting)*, press 1 (off) or 2 (on), then press #.

The display flashes the entered setting, then stops after pressing # and displays *LOW LEVEL RPTS OFF/ON (new setting)*.

LOW LEVEL REPORTS (0102-CS PHONE 1, 0112-CS PHONE 2, 0122-CS PHONE 3)

**DEFAULTS: CS PHONE 1 = ON
CS PHONE 2 = OFF
CS PHONE 3 = OFF**

This setting determines whether the following conditions report to the central station:

Force Armed, Hardwire Zone Trouble (open or short), Supervisory (wireless sensors), Low Battery (wireless sensors and touchpads).

Turning On or Off

With the display showing *LOW LEVEL RPTS OFF/ON (current setting)*, press 1 (off) or 2 (on), then press #.

The display flashes the entered setting, then stops after pressing # and displays *LOW LEVEL RPTS OFF/ON (new setting)*.

NEXT PHONE TEST (0303)

DEFAULT = 7 DAYS

This setting determines how many days (001 - 255) until the next automatic phone test occurs.

Programming

When setting up Phone Test Freq. (see above), Next Phone Test must be set to accurately count the number of days left in the cycle before the next phone test occurs. This setting should be the same or less than the Phone Test Freq. setting.

For U.L. Commercial Listed installations, this feature must be set to 1.

With the display showing *NEXT PHONE TEST nnn DAYS (current setting)*, enter the 3-digit value (001 - 255), then press #.

The display flashes the entered setting, then stops after pressing # and displays *NEXT PHONE TEST nnn DAYS (new setting)*.

NO ACTIVITY (0612—PARTITION 1, 0622—PARTITION 2)

DEFAULT = OFF

This setting determines whether the panel sends a no activity report to the central station or pager, if there is no system activity within a preset time period (see **TIMERS—ACTIVITY TIMEOUT**).

Turning On or Off

With the desired partition selected, press **B** until the display shows *NO ACTIVITY OFF/ON (current setting)*.

Press **1** (off) or **2** (on), then press #.

The display flashes the entered setting, then stops after pressing # and displays *NO ACTIVITY OFF/ON (new setting)*.

OPEN/CLOSE REPORTS (0134-PAGER 1, 0144-PAGER 2, 0154-PAGER 3, 0164-PAGER 4, 0174-PAGER 5)

DEFAULT = OFF

This setting determines whether opening and closing reports are sent to a pager. When turned on, the panel sends a closing report when the system is armed and an opening report when the system is disarmed.

NOTE

To use this feature, the *OPENING REPORTS* and *CLOSING REPORTS* settings under the *REPORTING* menu must be turned on for that partition.

Turning On or Off

With the display showing *OPEN/CLOSE RPTS OFF/ON (current setting)*, press **1** (off) or **2** (on), then press #.

The display flashes the entered setting, then stops after pressing # and displays *OPEN/CLOSE RPTS OFF/ON (current setting)*.

OPEN/CLOSE REPORTS (0104-CS PHONE 1, 0114-CS PHONE 2, 0124-CS PHONE 3)

DEFAULTS: ALL OFF

This setting determines whether opening and closing reports are sent to the central station. When turned on, the panel sends a closing report when the system is armed and an opening report when the system is disarmed.

NOTE

To use this feature, the *OPENING REPORTS* and *CLOSING REPORTS* settings under the *REPORTING* menu must be turned on for that partition.

Turning On or Off

With the display showing *OPEN/CLOSE RPTS OFF/ON (current setting)*, press **1** (off) or **2** (on), then press #.

The display flashes the entered setting, then stops after pressing # and displays *OPEN/CLOSE RPTS OFF/ON (new setting)*.

OPENING REPORTS (0610—PARTITION 1, 0620—PARTITION 2)

DEFAULT = OFF

This setting determines whether the panel sends an opening report to the central station or pager, after the partition is disarmed.

NOTE

To use this feature, the *OPEN/CLOSE REPORTS* settings under the *PHONES—CS PHONE 1-3* and/or *PHONES—PAGER PHONE 1-5* menus must be turned on for the specific CS Phone or Pager Phone number.

Turning On or Off

With the desired partition selected, press **B** until the display shows *OPENING REPORTS OFF/ON (current setting)*.

Press **1** (off) or **2** (on), then press #.

The display flashes the entered setting, then stops after pressing # and displays *OPENING REPORTS OFF/ON (new setting)*.

CONCORD
Programming

OUTPUT TRIP TIME (0304)

DEFAULT = 04 SECONDS

This setting determines how long onboard, SnapCard, and HOM outputs are activated, when configured for a momentary trip.

Programming

With the display showing *OUTPUT TRIP TIME nn SECONDS (current setting)*, enter the desired time (1 - 12), then press #. The display flashes the entered setting, then stops after pressing # and displays *HOM TRIP TIME nn SECONDS (new setting)*.

PAGER DELAY (0205)

DEFAULT = 15 SECONDS

This setting determines how long a report is delayed to a pager (00 - 30 seconds), after the panel dials the pager number.

NOTE

The Pager Delay time should not be set below 5 seconds, unless absolutely necessary.

Programming

With the display showing *PAGER DELAY nn (current setting)*, enter a two digit time (00 - 30), then press #. The display flashes the entered setting, then stops after pressing # and displays *PAGER DELAY nn (new setting)*.

PAGER PHONE NUMBER (0130-PAGER 1, 0140-PAGER 2, 0150-PAGER 3, 0160-PAGER 4, 0170-PAGER 5)

DEFAULT = NONE

This setting is used for programming a phone number that communicates to a pager. Phone numbers can be 1 to 24 digits long and include pauses, call-waiting disable (*70), skylink number, and 7-digit PIN number.

NOTE

Phone numbers that disable call-waiting (*70) must be programmed using ITI ToolBox.

Programming

With the display showing *PHONE NUMBER _ (or current number)*, enter the desired pager phone number including pauses (press C for 3-second pause), then press #.

The display flashes the entered number, then stops after pressing # and displays *PHONE NUMBER (new number)*.

Deleting

With the display showing *PHONE NUMBER (current number)*, press D.

The display shows *PHONE NUMBER _*.

PARTITION ASSIGNMENT (0137-PAGER 1, 0147-PAGER 2, 0157-PAGER 3, 0167-PAGER 4, 0177-PAGER 5)

DEFAULT = 1

This setting determines the partition that reports to a pager. Both partitions can be assigned to report to a single pager.

Programming

With the display showing *PTN ASSIGNMENT 1/2/12 (current setting)*, press 1 or 2 to select partition 1 or 2 or press 1 and 2 to select both, then press #.

The display flashes the entered setting, then stops after pressing # and displays *PTN ASSIGNMENT 1/2/12 (new setting)*.

PARTITION MASTER CODE (010—PARTITION 1, 011—PARTITION 2)

DEFAULT = NONE

The Partition Master Code performs all partition and user programming functions in the specific partition.

Programming

- With the display showing *USER CODES*, press #. The display shows *REGULAR USER CODES*.
- Press **A** or **B** until the display shows *PARTITION MASTER CODE*.
- Press # and the display shows *PARTITION nnnn (current code)*.
- Enter a new 4-digit partition master code, then press #.

The display flashes the entered code, then stops after pressing # and displays *PARTITION nnnn (new code)*.

Deleting

While in the specific partition, enter user programming with the system master code ([9] + [C][O][D][E]). The display shows *USER CODES*.

Press **A** or **B** until the display shows *PARTITION MASTER CODES*, then press #. The display shows *PARTITION nnnn (current code)*.

Enter the 4-digit system master code, then press #.

The display flashes the entered code, then stops after pressing # and displays *PARTITION **** (no code)*.

PHONE ACC. KEY (0215—PARTITION 1, 0225—PARTITION 2)

DEFAULT = #

This setting determines which touch-tone phone button is used for system access and control (only if a Phone Interface and Voice module is installed). To access the system, the user picks up the phone and within five seconds presses #. The panel seizes the phone line and waits for the user to enter security system commands. Phone access can be changed from # to *.

NOTE

To keep conflicts between the security system and other phone devices and services to a minimum, it is strongly recommended not to change the phone access to *. Since many phone devices (answering machines, computer modems, fax machines) and services (call-waiting, call-forwarding, banking transactions) require * to initiate their operation, # is set as the default to help reduce conflicts.

Programming

With the desired partition selected, press **B** until the display shows *PHONE ACCESS #/* (current setting)*.

Press **1** (for *) or **2** (for #), then press #.

The display flashes the entered setting, then stops after pressing # and displays *PHONE ACCESS #/* (new setting)*.

PHONE NUMBER (0100-CS PHONE 1, 0110-CS PHONE 2, 0120-CS PHONE 3)

DEFAULT = NONE

This setting is used for programming the central station receiver's phone number. Phone numbers can be 1 to 24 digits long, including pauses. To enter pauses, press C.

NOTE

The PHONE NUMBER menus are not accessible if a Dealer Code is programmed and the Installer Code is used to enter installer programming mode. To access these menus when a Dealer Code is programmed, you must enter installer programming mode using the Dealer Code.

NOTE

Phone numbers that disable call-waiting (*70) must be programmed using ITI ToolBox.

Programming

With the display showing *PHONE NUMBER _ (or current number)*, enter the desired phone number + #.

The display flashes the entered number, then stops after pressing # and displays *PHONE NUMBER (new number)*.

Deleting

With the display showing *PHONE NUMBER (current number)*, press **D**.

The display shows *PHONE NUMBER _*.

CONCORD
Programming

PHONE NUMBER (0180)

DEFAULT = NONE

This setting is used for programming the phone number of a computer used for programming the panel from off-site. Phone numbers can be 1 to 24 digits long, including pauses. To enter pauses, press C.

Programming

With the display showing *PHONE NUMBER (current number)*, enter the desired phone number + #.

The display flashes the entered number, then stops after pressing # and displays *PHONE NUMBER (new number)*.

PHONE PANIC (0214—PARTITION 1, 0224—PARTITION 2)

DEFAULT = OFF

This setting determines whether a police panic alarm can be activated from a touch-tone phone. When turned on, pressing **# + *[*][*][*][*][*][*]** activates a police panic alarm.

Turning On or Off

With the desired partition selected, press **B** until the display shows *PHONE PANIC OFF/ON (current setting)*.

Press **1** (off) or **2** (on), then press #.

The display flashes the entered setting, then stops after pressing # and displays *PHONE PANIC OFF/ON (new setting)*.

PHONE TEST (0200)

DEFAULT = ON

This setting determines if the user can, at any time, test the communication from the panel to the central station or a pager by entering **8 + CODE + 2** (# + 8 + CODE + 2 from a touch-tone phone).

NOTE

For U.L. Commercial Listed installations (UL 1610), this feature must be on.

Turning On or Off

With the display showing *PHONE TEST OFF/ON (current setting)*, press **1** (off) or **2** (on), then press #.

The display flashes the entered setting, then stops after pressing # and displays *PHONE TEST OFF/ON (new setting)*.

PHONE TEST FREQUENCY (0302)

DEFAULT = 7 DAYS

This setting determines how often the panel sends the automatic phone test (see Auto Phone Test under Phone Options—Global) to the central station or a pager. The phone test frequency can be set to report every 1 to 255 days.

NOTE

For U.L. Commercial Listed installations, this feature must be set to 1.

Programming

With the display showing *PHONE TEST FREQ nnn DAYS (current setting)*, enter the 3-digit value (001 - 255), then press #.

The display flashes the entered setting, then stops after pressing # and displays *PHONE TEST FREQ nnn DAYS (new setting)*.

RECEIVER FAILURE (06008)

DEFAULT = OFF

This setting determines whether the panel reports if no wireless sensor signals have been received for two hours, or if the receiver is being jammed (constant signal).

NOTE

For U.L. Listed installations that include wireless devices, this feature must be on.

Turning On or Off

With the display showing *RECEIVER FAILURE OFF/ON (current setting)*, press **1** (off) or **2** (on), then press #.

The display flashes the entered setting, then stops after pressing # and displays *RECEIVER FAILURE OFF/ON (new setting)*.

REMOTE ACCESS (0210—PARTITION 1, 0220—PARTITION 2)

DEFAULT = ON

This setting determines whether users can access and control the system from an off-site phone.

Turning On or Off

With the desired partition selected, press **B** until the display shows *REMOTE ACCESS OFF/ON (current setting)*.

Press **1** (off) or **2** (on), then press **#**.

The display flashes the entered setting, then stops after pressing **#** and displays *REMOTE ACCESS OFF/ON (new setting)*.

RF CHECK-IN TIME (0301)

DEFAULT = 12 HOURS

This setting determines how many hours (2 - 24) the panel has to receive at least one signal from a wireless sensor (learned into a supervised group). If the panel does not receive a signal from any supervised wireless sensor within the set time, the panel reports a supervisory condition to the central station.

NOTE

For U.L. Listed commercial installations, the RF Tx Timeout must be set to 4 hours. For U.L. Listed residential installations, the RF Tx Timeout must be set to 24 hours.

Programming

With the display showing *RF TX TIMEOUT nn HOURS (current setting)*, enter the desired 2-digit timeout value (02 - 24), then press **#**.

The display flashes the entered setting, then stops after pressing **#** and displays *RF TX TIMEOUT nn HOURS (new setting)*.

RF LOW BATTERY REPORT (06009)

DEFAULT = WEEKLY

This setting determines whether the panel reports to the central monitoring station or pager daily or weekly, when a wireless sensor or touchpad reports a low battery condition to the panel.

Programming

With the display showing *RF LOW BAT RPT DAILY/WEEKLY (current setting)*, press **1** (daily) or **2** (weekly), then press **#**.

The display flashes the entered setting, then stops after pressing **#** and displays *RF LOW BAT RPT DAILY/WEEKLY (new setting)*.

RF SUPERVISOR REPORT (06010)

DEFAULT = WEEKLY

This setting determines whether the panel reports to the central monitoring station or pager daily or weekly, when the panel detects a wireless sensor supervisory condition.

With the display showing *RF SUPV REPORT DAILY/WEEKLY (current setting)*, press **1** (daily) or **2** (weekly), then press **#**. The display flashes the entered setting, then stops after pressing **#** and displays *RF SUPV REPORT DAILY/WEEKLY (new Ring/*

RF TOUCHPAD SUPERVISION (0500)

DEFAULT = OFF

This setting determines whether the panel monitors for and reports supervisory conditions of Wall-mount Wireless Touchpads.

When turned on, the panel monitors Wall-mount Wireless Touchpads for supervisory signals (based on RF TX Timeout setting). If the panel does not receive a supervisory signal from the touchpad within the RF TX Timeout setting or if a low touchpad battery condition is detected, the system alerts users and reports a supervisory condition to the central monitoring station.

NOTE

The system alerts users if a low battery condition on any wireless touchpad occurs, whether this setting is off or on.

Turning On or Off

With the desired partition selected, press **B** until the display shows *RFTP SUPERVISION OFF/ON (current setting)*.

Press **1** (off) or **2** (on), then press **#**.

The display flashes the entered setting, then stops after pressing **#** and displays *RFTP SUPERVISION OFF/ONN (new setting)*.

CONCORD Programming

SENSOR TEXT (081)

DEFAULT = NONE

Use the following guidelines for programming text to identify zone/sensor locations.

- There are 16 character/word locations or “Item Numbers” for each zone/sensor name. Item numbers for each character/word appear on the next page.
- If a desired word does not appear in the list, create it using characters (custom text). *However, custom text is not spoken by the panel. Instead, a pause in speech occurs in the voice message.*
- When using words, spaces between them appear automatically. When creating words using characters, you must reserve an item number for a ‘space’ after creating the word.
- Each character or word uses up one item number. For example, a word from the list counts as one item number. A created word, such as BOY’S counts as six item numbers—4 letters, 1 apostrophe, and 1 space.
- Plan ahead before programming sensor text. You may need to abbreviate words you create, to avoid running out of item numbers.

Programming

- With the display showing *LEARN SENSORS*, press **B** until the display shows *SENSOR TEXT*. Press # and the display shows *TEXT FOR SN 01*. Press # and the display shows:
Sn 01 ITEM 00
000 -
where *ITEM 00* is the first character/word location and *000* is the 3-digit character/word number.
- Enter the 3-digit number of the desired character/word or scroll forward through the numbers by pressing **B** or backward by pressing **A**. If you make a mistake, simply enter the correct 3-digit number or continue scrolling through choices.
- Press # to accept the displayed choice and the display shows:
Sn 01 ITEM 01
000 -
- Repeat steps 4 and 5 as needed to complete the zone/sensor name.
- Press * after entering the last 3-digit character/word number. The display shows the complete text name. For example:
TEXT FOR SN 01
FRONT ENTRY DOOR

SIA/CID REPORTING (0106-CS PHONE 1, 0116-CS PHONE 2, 0126-CS PHONE 3)

DEFAULTS: ALL CID

This setting determines whether the panel uses the SIA or CID (Contact ID) reporting format for central station communication.

Programming

With the display showing *REPORTING FORMAT SIA/CID (current setting)*, press **1** (for SIA) or **2** (for CID), then press #. The display flashes the entered setting, then stops after pressing # and displays *REPORTING FORMAT SIA/CID (new setting)*.

SILENT TALKBACK (0903)

DEFAULT = OFF

This setting determines whether the central station operator can speak to persons on the premises (on) or only listen (off) during a silent or duress alarm audio session.

Turning On or Off

With the display showing *AUDIO VERIFICATION OFF/ON*, press **B** until the display shows *SILENT TALKBACK OFF/ON (current setting)*.

Press **1** (off) or **2** (on), then press #.

The display flashes the entered setting, then stops after pressing # and displays *SILENT TALKBACK OFF/ON (new setting)*.

SIREN TIMEOUT (0313—PARTITION 1, 0323—PARTITION 2)

DEFAULT = 04 MINUTES

This setting determines how long sirens sound (01 - 30 minutes) if no one is present to disarm the system.

Programming

With the desired partition selected, press **B** until the display shows *SIREN TIMEOUT nn MINUTES (current setting)*.

Enter the desired time value, then press #.

The display flashes the entered setting, then stops after pressing # and displays *SIREN TIMEOUT nn MINUTES (new setting)*.

SIREN VERIFY (0710)

DEFAULT = OFF

This setting determines whether the panel monitors speakers connected to panel terminals 7 and 8.

NOTE

For UL Listed installations, this feature must be on.

Turning On or Off

With the display showing *SIREN VERIFY OFF/ON (current setting)*, press **1** (off) or **2** (on), then press #.

The display flashes the entered setting, then stops after pressing # and displays *SIREN VERIFY OFF/ON (new setting)*.

SMOKE VERIFY (1100)

DEFAULT = OFF

This setting determines whether the panel requires two alarm signals within five minutes (on) from 2- or 4-wire smoke detectors connected to panel zone input 8 and/or SnapCard zone inputs, before activating system sirens and reporting to a central station or pager.

NOTE

For California State Fire Marshall Listed installations, this feature must be off.

Turning On or Off

With the display showing *ONBOARD OPTIONS*, press #. The display shows *SMOKE VERIFY OFF/ON (current setting)*.

Press **1** (off) or **2** (on), then press #.

The display flashes the entered number, then stops after pressing # and shows *SMOKE VERIFY OFF/ON (new setting)*.

STREAMLINING (0136-PAGER 1, 0146-PAGER 2, 0156-PAGER 3, 0166-PAGER 4, 0176-PAGER 5)

DEFAULT = ON

This setting determines whether the panel includes (off) or excludes (on) the account number when reporting to a pager.

Turning On or Off

With the display showing *STREAMLINING OFF/ON (current setting)*, press **1** (off) or **2** (on), then press #.

The display flashes the entered setting, then stops after pressing # and displays *STREAMLINING OFF/ON (new setting)*.

STAR IS NO DELAY (0514—PARTITION 1, 0524—PARTITION 2)

DEFAULT = OFF

This setting determines whether the keychain touchpad star button controls a hardwire output (off) or the NO DELAY feature (on).

Programming

With the desired partition selected, press **B** until the display shows *STAR IS NO DELAY OFF/ON (current setting)*.

Press **1** (off) or **2** (on), then press #. The display flashes the entered setting, then stops after pressing # and displays *STAR IS NO DELAY OFF/ON (new setting)*.

CONCORD Programming

SUPERVISORY TIME (0300)

DEFAULT = RANDOM FROM 01:00 TO 05:00

This setting determines what time of day the panel reports supervisory and low battery reports to the central station. The setting is based on a 24-hour timer so a.m. and p.m. settings are not needed.

NOTE

The panel's clock must be set with the correct time for accurate supervisory time reporting. Refer to the "User Programming" section for setting the panel's clock.

Programming

With the display showing *SUPERVISORY TIME HH:MM (current setting)*, enter the desired 4-digit time value (for example, enter 0130 to set the supervisory time for 1:30 a.m.), then press #.

The display flashes the entered setting, then stops after pressing # and displays *SUPERVISORY TIME (new setting)*.

SYSTEM MASTER CODE (020)

DEFAULT = 1234

The System Master Code performs all system functions in all partitions and in user programming.

Programming

- Enter user programming mode with the System Master CODE.
- With the display showing *USER CODES*, press #. The display shows *REGULAR USER CODES*.
- Press **A** or **B** until the display shows *SYSTEM MASTER CODE*.
- Press # and the display shows *SYSTEM MASTER 1234* (or current code).
- Enter a new 4-digit system master code, then press #.

The display flashes the entered code, then stops after pressing # and displays *SYSTEM MASTER nnnn (new code)*.

SYSTEM TAMPER (0618—PARTITION 1, 0628—PARTITION 2)

DEFAULT = OFF

This setting determines whether the armed partition goes into alarm if several incorrect access codes (40 consecutive key presses) are entered. This setting also determines whether the panel reports to the central station if a bus device stops communicating with the panel.

NOTE

For U.L. Commercial Listed installations, this feature must be on.

Programming

With the desired partition selected, press **B** until the display shows *SYSTEM TAMPER OFF/ON (current setting)*.

Press **1** (off) or **2** (on), then press #. The display flashes the entered setting, then stops after pressing # and displays *FIRE PANIC OFF/ON (new setting)*.

SWS SUPERVISOR CODE (0703)

DEFAULT = 003

This setting determines the system house code number used for supervising wireless sirens.

NOTE

To supervise wireless sirens, Concord hardwire panels must include a SuperBus RF Receiver. For all Concord panels, the siren must be learned into sensor group 33 for the system to process radio signals from wireless sirens.

Supervised Wireless Sirens receive signals from the panel through the existing electrical wiring. If sirens fail to receive or process these signals, the siren transmits a wireless signal to the panel/ receiver.

NOTE

You must set SWS Supv Code and the partition House Code (see the *LIGHT CONTROL* menu) *before* plugging in Supervised Wireless Sirens.

Programming

With the display showing *SWS SUPV CODE nnn (current code)*, enter the desired code (1 - 255), then press #.

The display flashes the entered code, then stops after pressing # and displays *SWS SUPV CODE nnn (new code)*.

TOLL SAVER (0213—PARTITION 1, 0223—PARTITION 2)

DEFAULT = ON

This setting determines whether the panel answers off-site access on the eighth ring (on) or twelfth ring (off), if a trouble condition exists.

Turning On or Off

With the desired partition selected, press **B** until the display shows *TOLL SAVER OFF/ON (current setting)*.

Press **1** (off) or **2** (on), then press **#**.

The display flashes the entered setting, then stops after pressing **#** and displays *TOLL SAVER OFF/ON (new setting)*.

TOUCHPAD POLICE PANIC (0512—PARTITION 1, 0522—PARTITION 2)

DEFAULT = ON

Programming

This setting determines whether the police panic buttons are enabled (on) or disabled (off) on touchpads for a selected partition.

With the desired partition selected, press **B** until the display shows *POLICE PANIC OFF/ON (current setting)*. Press **1** (off) or **2** (on), then press **#**. The display flashes the entered setting, then stops after pressing **#** and displays *POLICE PANIC OFF/ON (new setting)*.

UL 98 OPTIONS (0702)

DEFAULT = OFF

This setting determines whether the panel complies with UL 98 requirements (4-hour trouble beep restart, 4-hour backup battery test, 4-hour smoke (group 26) supervisory zone).

NOTE

For UL Listed installations, this feature must be on.

Turning On or Off

With the display showing *UL 98 OPTIONS OFF/ON (current setting)*, press **1** (off) or **2** (on), then press **#**.

The display flashes the entered setting, then stops after pressing **#** and displays *UL 98 OPTIONS OFF/ON (new setting)*.

VIEW SENSORS (083)

DEFAULT = NONE

This menu lets you view the assignments for each learned zone/sensor. For example, the display shows:

S01 P1 G13 NC
BACK DOOR

where S01 = zone/sensor number, P1 = partition 1, G13 = sensor group 13, NC = normally closed, HW = hardwired, and DEN DOOR is the programmed text name.

Programming

With the display showing *LEARN SENSORS*, press **B** until the display shows *VIEW SENSORS*.

Press **#** and the display shows the lowest sensor number zone/sensor assignments.

Press **A** or **B** to scroll through all learned zone/sensor number assignments.

TWO-WIRE SMOKE (1101)

DEFAULT = OFF

This setting determines whether panel zone input 8 is set up for 2-wire smoke detectors (on) or for standard intrusion or 4-wire smoke detectors (off).

NOTE

If 2-wire smoke detectors are connected to hardwire zone input 8, this setting must be turned on *before* entering the LEARN SENSORS menu.

Turning On or Off

With the display showing *ONBOARD OPTIONS*, press **#**. The display shows *TWO WIRE SMOKE OFF/ON (current setting)*.

Press **1** (off) or **2** (on), then press **#**.

The display flashes the entered number, then stops after pressing **#** and shows *TWO WIRE SMOKE OFF/ON (new setting)*.

CONCORD
Programming

QUICK ARM (0011—PARTITION 1, 0021—PARTITION 2)

DEFAULT = OFF

Programming

Quick Arm allows system arming without using an access code. When turned on, the system arming level can be increased from Level 1-OFF to LEVEL 2-STAY, from Level 1-OFF to LEVEL 3-AWAY, or from Level 2-STAY to LEVEL 3-AWAY without entering an access code. A valid access code is still required to decrease the arming level or disarm the system.

Turning On or Off

With the desired partition selected, press **B** until the display shows *QUICK ARM OFF/ON (current setting)*.

Press **1** (off) or **2** (on), then press **#**.

The display flashes the entered setting, then stops after pressing **#** and displays *QUICK ARM OFF/ON (new setting)*.

ZONE RESTORALS (06006)

DEFAULT = OFF

This setting determines whether the panel reports a restoral to the central monitoring station or pager for wireless or hardwire zones in alarm, before the alarm is canceled.

NOTE

As with all ITI panels, hardwire smoke detectors connected to Concord or SnapCard hardwire zones do not send restorals.

Turning On or Off

With the display showing *ZONE RESTORALS OFF/ON (current setting)*, press **1** (off) or **2** (on), then press **#**.

The display flashes the entered setting, then stops after pressing **#** and displays *ZONE RESTORAL OFF/ON (new setting)*.

Learning Sensors

This task illustrates *learning* wireless and hardwired sensors for the Concord system.

1. Choose the group for each sensor. Use the questions below and the chart on page 4-39 to decide which group.
 - Does the sensor need a delay?
 - Should the sensor be supervised?
 - At what level should the sensor be active?
2. Enter program mode.
3. If necessary, press **A** until the system displays:

SYSTEM
PROGRAMMING

4. Press **#**. The system displays:

SECURITY

5. Press **B** until the system displays:

SENSORS

6. With the system displaying **SENSORS**, press **#**.
The system displays:

LEARN SENSORS

7. Press **#** and the system displays:

SENSOR PTN
1

NOTE
Press **08 + #** to go directly to the Sensors Menu.

8. Press **#** to select partition 1 or press **2 + #** to select partition 2.

The system displays

SENSOR GROUP 00

NOTE

See page for a description of all sensor group characteristics.

NOTE

nn is the displayed (next available) sensor number.

9. Enter the desired 2-digit sensor group + **#**.

The system displays:

TRIP SENSOR NN

10. To change the displayed sensor number, enter the desired 2-digit sensor number, then press **#**.
11. With the desired sensor number displayed, trip the sensor or zone as follows:
 - **Hardwire Zones:** trip the zone into the alarm state.
 - **Wireless Sensors:** follow the instructions included with each sensor or see page 4-41 for a list of common wireless sensors and how to trip them.
 - **Wireless Door/Window Sensors with External Contacts:** place the external contact in the alarm condition, then activate the sensor's tamper switch.
12. Continue tripping sensors to learn them into the selected sensor group and partition. To stop learning sensors into this group and partition, press ***** twice and start again from step 5 (**LEARN SENSORS**) to learn sensors into another group and partition.

Student Notes

Sensor Group Characteristics Table

No.	Name	Application	Alarm	Delay	Restoral	Supervisory	CS Report	Chime	Active Levels
00	Fixed Panic	24-hour audible fixed emergency buttons.	Police	Instant		✓	✓		1, 2, 3
01	Portable Panic	24-hour audible portable emergency buttons.	Police	Instant			✓		1, 2, 3
02	Fixed Panic	24-hour silent fixed emergency buttons.	Silent	Instant		✓	✓		1, 2, 3
03	Portable Panic	24-hour silent portable emergency buttons.	Silent	Instant			✓		1, 2, 3
04	Fixed Auxiliary	24-hour auxiliary sensor, such as Pendant Panic or holdup button.	Auxiliary	Instant		✓	✓		1, 2, 3
05	Fixed Auxiliary	24-hour auxiliary emergency button. Siren shutoff confirms CS report.	Auxiliary	Instant		✓	✓		1, 2, 3
06	Portable Auxiliary	24-hour portable auxiliary alert button.	Auxiliary	Instant			✓		1, 2, 3
07	Portable Auxiliary	24-hour portable auxiliary button. Siren shutoff confirms CS report.	Auxiliary	Instant			✓		1, 2, 3
08	Special Intrusion	Special belongings, such as gun cabinets and wall safes.	Police	Instant	✓	✓	✓		1, 2, 3
09	Special Intrusion	Special belongings, such as gun cabinets and wall safes.	Police	Standard	✓	✓	✓		1, 2, 3
10	Entry/Exit Delay	Entry and exit doors that require a standard delay time.	Police	Standard	✓	✓	✓	✓	2, 3
11	Entry/Exit Delay	Garage doors and entrances that require an extended delay time. *	Police	Extended	✓	✓	✓	✓	2, 3
12	Entry/Exit Delay	Driveway gates and entrances that require a twice extended delay time. *	Police	Twice Extended	✓	✓	✓	✓	2, 3
13	Instant Perimeter	Exterior doors and windows.	Police	Instant	✓	✓	✓	✓	2, 3
14	Instant Interior	Interior doors.	Police	Follower	✓	✓	✓		2, 3
15	Instant Interior	Interior PIR motion sensors. *	Police	Follower		✓	✓		2, 3
16	Instant Interior	Interior doors.	Police	Follower	✓	✓	✓		3

CONCORD
Programming

No.	Name	Application	Alarm	Delay	Restoral	Supervisory	CS Report	Chime	Active Levels
17	Instant Interior	PIR motion sensors. *	Police	Follower		✓	✓		3
18	Instant Interior	PIR motion sensors subject to false alarms. * †	Police	Follower		✓	✓		3
19	Delayed Interior	Interior doors that initiate a delay before going into alarm. *	Police	Standard	✓	✓	✓		3
20	Delayed Interior	PIR motion sensors that initiate a delay before going into alarm. *	Police	Standard		✓	✓		3
21	Local Instant Interior	24-hour local alarm zone protecting anything that opens and closes.	Police	Instant	✓	✓			1, 2, 3
22	Local Delayed Interior	Same as group 21, plus activation initiates a delay before going into alarm.	Police	Standard	✓	✓			1, 2, 3
23	Local Instant Auxiliary	24-hour local alarm zone protecting anything that opens and closes. ‡	Auxiliary	Instant	✓	✓			1, 2, 3
24	Local Instant Auxiliary	24-hour local alarm zone protecting anything that opens and closes. Sirens shut off at restoral. *	Auxiliary	Instant	✓	✓			1, 2, 3
25	Local Special Chime	Notify the user when a door is opened. Sounds emit from a local annunciator. *	Special Chime	Instant		✓			1, 2, 3
26	Fire	24-hour fire, rate-of-rise heat, and smoke sensors. §	Fire	Instant	✓	✓	✓		1, 2, 3
27	Output Module	Hardwire Output Module (HOM) lamp control or other customer feature. ‡	Silent	Instant	✓	✓			1, 2, 3
28	Output Module	HOM, PIR motion sensor, sound sensor, or pressure mat. ‡	Silent	Instant		✓			1, 2, 3
29	Auxiliary	Freeze sensor.	Auxiliary	Instant	✓		✓		1, 2, 3
32	Output Module	HOM, PIR motion sensor, sound sensor, or pressure mat. ‡	Silent	Instant					1, 2, 3
33	Siren	Wireless Siren Supervision. ‡	Silent	Instant		✓	✓		1, 2, 3
34	Gas	Carbon monoxide (CO) Gas Detectors ‡	Auxiliary	Instant	✓	✓	✓		1, 2, 3

Note: Check marks (✓) represent characteristics present in a group.

* This group is not certified as a primary protection circuit for UL-listed systems and is for supplementary use only.

† Sounds instant police siren if two or more sensors are tripped within 4 minutes. Otherwise sensors are followers to delayed sensors. If Alarm Verification is on, group 18 functions like group 17.

‡ This group has not been investigated by UL.



§ This group is required for UL-listed residential fire alarm applications.

Tripping Learn Mode Wireless Sensors

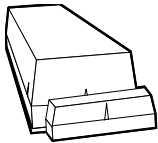
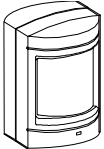
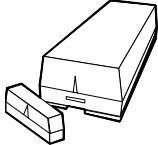
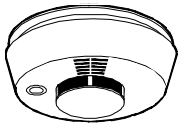
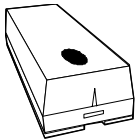
This task illustrates tripping the most common wireless sensors.

Sensor	Do This to Trip the Sensor
<p>Crystal Door Window</p> 	Remove the sensor cover.
<p>SAW Door/Window</p>	Remove the sensor cover and press the <i>Press to Program</i> button.
<p>PIR Motion</p> 	Remove the sensor cover
<p>Shock</p> 	Remove the sensor cover
<p>System Smoke</p> 	Press and hold the test button until the system sounds transmission beeps.
<p>Freeze</p> 	Remove the sensor cover

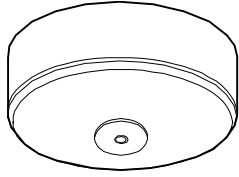
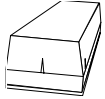
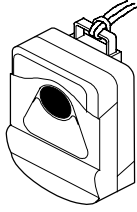
CONCORD
Programming

Sensor	Do This to Trip the Sensor
<p>Rate-of-rise Heat Detector</p> 	<p>Press the Learn switch.</p>
<p>Glass Guard</p> 	<p>Remove the sensor cover</p>
<p>Emergency Panics</p> 	<p>Press and hold the appropriate panic button(s) for 3 full seconds.</p>
<p>Key Chain Touchpads</p> 	<p>Press and hold the lock and unlock key simultaneously.</p>
<p>NOTE Refer to the particular sensor's installation instructions for more details on tripping Learn Mode wireless sensors.</p>	

Viewing Sensor Information

This task illustrates viewing information about the sensors that have already been added to the system. Use this procedure to find the following information about each sensor:

- Sensor number
- Partition the sensor is in
- Group the sensor is assigned
- Normally open or normally closed
- Hardwired or wireless
- Sensor text (if any)

1. Enter program mode.
2. Press **A** until the system displays:

SYSTEM
PROGRAMMING

3. Press **#**. The system displays:

SECURITY

4. Press **B** until the system displays:

SENSORS

5. With the system displaying **SENSORS**, press **#**.
The system displays:

LEARN SENSORS

6. Press **B** until the system displays:

VIEW SENSORS

NOTE

Press 08 + # to go directly to the Sensors Menu.

7. Press #.

The system displays the first sensor's information. For example:

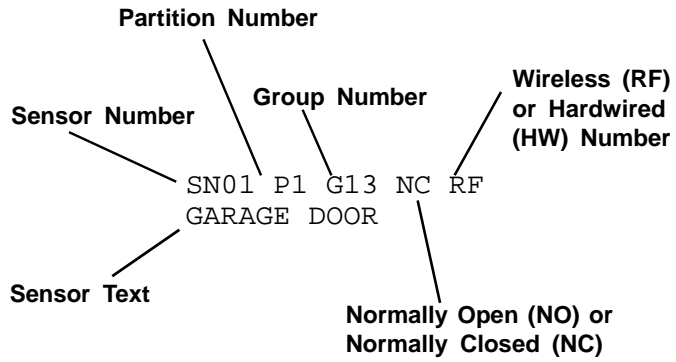

8. Press **B** to see the next sensor's information or enter the sensor number as a shortcut.

Verifying the Bus Device Unit Numbers

This task illustrates displaying the unit numbers for each bus device connected to the Concord panel.

Each bus device must have a different unit number set on the device before programming. Usually, you must set this using DIP switches on the bus device. Refer to the installation instructions shipped with the bus device to set the unit ID. This procedure shows you how to see which devices the system found.

1. Enter program mode.
2. Press **A** until the system displays:

SYSTEM
PROGRAMMING

3. Press **#**. The system displays:

SECURITY

4. Press **B** until the system displays:

ACCESSORY
MODULES

5. Press **#** and the system displays:

BUS DEVICES

6. Press **#** and the system displays:

UNIT - TYPE
00 - RCVR

7. Press **A** or **B** to display the other bus devices that are assigned. For example:

UNIT - TYPE
03 - LTP

8. Press **#** to view or change the touchpad partition assignment. Press **1** or **2** to select the partition, then press **#** to enter the selection.

9. Press ***** to exit the Bus Device menu item.

NOTE

Press **10 + #** to go directly to the Accessory Modules Menu.

Bus Device Unit Number Codes

- ATP Alphanumeric Touchpad
- LTP LED Touchpad
- HIM Hardwire Input Module
- HOM Hardwire Output Module
- PIV Phone Interface/Voice Module
- RCVR Wireless Receiver
- ESM Energy Saver Module

Changing the Bus Device Unit Number for an ATP (Alphanumeric Touchpad)

This task illustrates changing the Bus Device Address of an alphanumeric touchpad.

1. Exit all programming menus. The touchpad will display:

TIME
DATE

2. Press and hold both **D** and **6** simultaneously until the touchpad displays:

DA001

3. Press **#**. The system displays:

DA_

NOTE

You must perform a scan bus for the the touchpad to function. In normal operation mode, enter 8 + 4321 (install Code) + 01 from a functioning touchpad.

4. Enter the new Bus Device Address (Range 001 to 015) then press **#**. The touchpad displays:

DA002

5. Press ***** to exit.

If this does not bring the touchpad back into the system, power Concord down and reapply power. Concord performs a scan bus at power up.

Deleting a Bus Driver Unit Number

This task illustrates deleting a Bus Device from a Concord CPU.

1. Enter program mode.
2. Press **A** until the system displays:

```
SYSTEM
PROGRAMMING
```

3. Press **#**. The system displays:

```
SECURITY
```

4. Press **B** until the system displays:

```
ACCESSORY
MODULES
```

5. Press **#**. The system displays:

```
BUS DEVICES
```

6. Press **#**. The system displays:

```
UNIT – TYPE
00 – RCVR
```

7. Use the **A** or **B** button to scroll to the device that is to be deleted.

```
UNIT – TYPE
07 – ATP
```

8. Press **D**. The system displays:

```
UNIT – TYPE
07 – NONE
```

9. Press ***** to exit the Bus Device Menu item.

System Configuration Worksheets

TABLE 4-2. System Event Trigger Numbers.

System Event	Trigger No.
Fire Alarm	001
Police Alarm	002
Auxiliary Alarm	003
Any Audible Alarm	004
Silent Alarm (sensor groups 2, 3, and duress)	005
Any Audible or Silent Alarm	006
HOM Group 27, 28, 32 in Alarm	007
Major Trouble (fail-to-communicate or receiver failure)	008
Arming to STAY or AWAY	009
Arming to AWAY	010
AVM is Interactive (audio session in progress)	011
Fail-to-Communicate (panel can't call CS or pager)	012
Partition 2 AVM Trip	013
Keychain Touchpad Star Button- Press	014
Smoke Power (when hardwire smokes need to be reset)	015

TABLE 4-3. Sensor Group Event Trigger Numbers.

Sensor Group	Trigger No.	Sensor Group	Trigger No.
Group 00 in alarm	064	Group 15 in alarm	079
Group 01 in alarm	065	Group 16 in alarm	080
Group 02 in alarm	066	Group 17 in alarm	081
Group 03 in alarm	067	Group 18 in alarm	082
Group 04 in alarm	068	Group 19 in alarm	083
Group 05 in alarm	069	Group 20 in Alarm	084
Group 06 in alarm	070	Group 21 in Alarm	085
Group 07 in alarm	071	Group 22 in alarm	086
Group 08 in alarm	072	Group 23 in alarm	087
Group 09 in alarm	073	Group 24 in alarm	088
Group 10 in alarm	074	Group 25 in alarm	089
Group 11 in alarm	075	Group 26 in alarm	090
Group 12 in alarm	076	Group 27 in alarm	091
Group 13 in alarm	077	Group 28 in alarm	092
Group 14 in alarm	078	Group 32 in alarm	096

TABLE 4-4. Sensor Number Event Trigger Numbers .

Sensor Number	State	Trigger Number	State	Trigger Number
Sensor 01	in alarm	129	open	229
Sensor 02	in alarm	130	open	230
Sensor 03	in alarm	131	open	231
Sensor 04	in alarm	132	open	232
Sensor 05	in alarm	133	open	233
Sensor 06	in alarm	134	open	234
Sensor 07	in alarm	135	open	235
Sensor 08	in alarm	136	open	236
Sensor 09	in alarm	137	open	237
Sensor 10	in alarm	138	open	238
Sensor 11	in alarm	139	open	239
Sensor 12	in alarm	140	open	240
Sensor 13	in alarm	141	open	241
Sensor 14	in alarm	142	open	242
Sensor 15	in alarm	143	open	243
Sensor 16	in alarm	144	open	244
Sensor 17	in alarm	145	open	245
Sensor 18	in alarm	146	open	246
Sensor 19	in alarm	147	open	247
Sensor 20	in alarm	148	open	248
Sensor 21	in alarm	149	open	249
Sensor 22	in alarm	150	open	250
Sensor 23	in alarm	151	open	251
Sensor 24	in alarm	152	open	252
Sensor 25	in alarm	153	open	253
Sensor 26	in alarm	154	open	254
Sensor 27	in alarm	155	open	255
Sensor 28	in alarm	156	open	256
Sensor 29	in alarm	157	open	257
Sensor 30	in alarm	158	open	258
Sensor 31	in alarm	159	open	259
Sensor 32	in alarm	160	open	260
Sensor 33	in alarm	161	open	261
Sensor 34	in alarm	162	open	262
Sensor 35	in alarm	163	open	263
Sensor 36	in alarm	164	open	264
Sensor 37	in alarm	165	open	265
Sensor 38	in alarm	166	open	266
Sensor 39	in alarm	167	open	267

CONCORD Programming

TABLE 4-4. Sensor Number Event Trigger Numbers (Continued).

Sensor Number	State	Trigger Number	State	Trigger Number
Sensor 40	in alarm	168	open	268
Sensor 41	in alarm	169	open	269
Sensor 42	in alarm	170	open	270
Sensor 43	in alarm	171	open	271
Sensor 44	in alarm	172	open	272
Sensor 45	in alarm	173	open	273
Sensor 46	in alarm	174	open	274
Sensor 47	in alarm	175	open	275
Sensor 48	in alarm	176	open	276
Sensor 49	in alarm	177	open	277
Sensor 50	in alarm	178	open	278
Sensor 51	in alarm	179	open	279
Sensor 52	in alarm	180	open	280
Sensor 53	in alarm	181	open	281
Sensor 54	in alarm	182	open	282
Sensor 55	in alarm	183	open	283
Sensor 56	in alarm	184	open	284
Sensor 57	in alarm	185	open	285
Sensor 58	in alarm	186	open	286
Sensor 59	in alarm	187	open	287
Sensor 60	in alarm	188	open	288
Sensor 61	in alarm	189	open	289
Sensor 62	in alarm	190	open	290
Sensor 63	in alarm	191	open	291
Sensor 64	in alarm	192	open	292
Sensor 65	in alarm	193	open	293
Sensor 66	in alarm	194	open	294
Sensor 67	in alarm	195	open	295
Sensor 68	in alarm	196	open	296
Sensor 69	in alarm	197	open	297
Sensor 70	in alarm	198	open	298
Sensor 71	in alarm	199	open	299
Sensor 72	in alarm	200	open	300
Sensor 73	in alarm	201	open	301
Sensor 74	in alarm	202	open	302
Sensor 75	in alarm	203	open	303
Sensor 76	in alarm	204	open	304

TABLE 4-5. Response Numbers.

Feature	State	Trigger Number	Feature	State	Trigger Number
Phone Test	In Alarm	205	No Activity	In Alarm	216
RF Touchpad Reports	In Alarm	206	Fire Panic	In Alarm	217
AC Failure	In Alarm	207	Police Panic	In Alarm	218
CPU Failure	In Alarm	208	Auxiliary Panic	In Alarm	219
Auto Phone Test	In Alarm	209	Opening Report	In Alarm	220
Receiver Failure	In Alarm	210	Closing Report	In Alarm	221
Back in Service	In Alarm	211	Latchkey Report	In Alarm	222
Phone Failure	In Alarm	212	Duress	In Alarm	223
Buffer Full	In Alarm	213	Forced Armed Report	In Alarm	224
System Tamper	In Alarm	214	Fire in Partition	In Alarm	225
Freeze	In Alarm	215			

TABLE 4-6. Response Numbers.

Siren Tracking	Trip Delay	Response Time	Response No.
no	no	momentary	00
no	no	3 minutes ⁵	01
no	no	siren time ²	02
no	no	sustained ³	03
no	yes ⁴	momentary	04
no	yes ⁴	3 minutes ⁵	05
no	yes ⁴	siren time ²	06
no	yes ⁴	sustained ³	07
yes ¹	no	momentary	08
yes ¹	no	3 minutes ⁵	09
yes ¹	no	siren time ²	10
yes ¹	no	sustained ³	11
yes ¹	yes ⁴	momentary	12
yes ¹	yes ⁴	3 minutes ⁵	13
yes ¹	yes ⁴	siren time ²	14
yes ¹	yes ⁴	sustained ³	15

Notes for 4-6, Response Number

1. If an event doesn't trigger sirens, siren tracking response numbers activate without turning on the output. If sirens are triggered by another event, the output pulses to match the siren. If siren cadence changes (for example, from police to fire), outputs set up for siren tracking change to match the siren and all pulsing outputs pulse to one common cadence. However, HOM outputs won't be synchronized with panel or SnapCards outputs or the panel speaker output.
2. If an event doesn't trigger siren response times the outputs activates only if sirens are active for another reason.
3. If an alarm event doesn't require disarming (no activity, closing report, etc.), outputs set up for a sustained response time remain activated until the next arming level change.
4. If an event occurs that activates an output set up for a trip delay, the delay and output activation can be cancelled by triggering the event restoral.
5. Activated outputs set up for a 3-minute response time remain active for the entire 3 minutes. To deactivate the output before the 3-minute response time expires, enter program mode or remove panel power. Activated outputs set up for a momentary or 3-minute response time restart if the same trigger occurs again.

CONCORD
Programming

Module 5-Testing the System

Introduction

This module teaches the installer how to test the Concord system after installation and programming. You should also test the system after any change in environment, equipment, or programming.

What's in This Module

Testing Sensors.....	5-2
Tripping Learn Mode Wireless Sensors.....	5-4
Correcting a Failed Sensor	5-6
Testing Telephone Communications.....	5-7
Testing Central Station/Pager Communication.....	5-8
Testing Outputs	5-9
Testing the Light Control.....	5-9
Testing the Energy Saver Module.....	5-10
Testing Exercise.....	5-10

Testing Sensors

This task illustrates testing sensors, zones, and touchpad panics after installing and programming them.

Perform this test after you finish programming all the sensors and whenever a sensor-related problem is suspected.

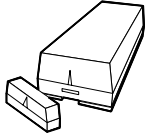

1. Place all zones/sensors in their secured (non-alarm) state.

2. At an alphanumeric touchpad, enter the sensor test mode by pressing **8 + Installer CODE + 3**.

The touchpad sounds one beep and displays:

*SENSOR TEST

The system stays in sensor test for 15 minutes. After 15 minutes the panel disarms automatically.

3. Trip each zone/sensor and touchpad panic one at a time and listen for hardwire touchpads and Supervised Wireless Interior Sirens to sound one long beep.

The display shows the sensor/zone name and OK. For example:

FRONT DOOR OK

If you have a speaker with phone interface/voice module installed, you will not hear beeps. Instead, you will hear:



"SENSOR NAME, OK."

NOTE

See next page for instructions on how to trip the different kinds of wireless sensors.

NOTE

See page for instructions on how to trip the different kinds of wireless sensors.

4. Press the **STATUS** button on the alphanumeric touchpad or press **# + *** on an on-premises phone when you believe all sensors/zones and panics have been tested.
5. The system announces any untested sensor numbers. For example, "Sensor test is on, sensor xx test, sensor xx test." Sensor xx test indicates which sensor(s) have not been tested. On the alphanumeric touchpad, the display will scroll through the untested sensors, for example:

15 TEST GARAGE DOOR
81 TEST POLICE PANIC

6. Test all untested sensors as above.

7. If all sensors have been tested, you will hear,



"SENSOR TEST IS ON. ALL SENSOR TEST IS OK."

8. If you need more time, enter **8 + Installer CODE + 3** at the alphanumeric touchpad while the system is still in sensor test.

This causes the system to stay in sensor test mode for another 15 minutes, preserving the list of untested sensors. After 15 minutes, the panel disarms.

9. To exit the sensor test, enter **1 + System Master CODE** or **Partition Master CODE** at the alphanumeric touchpad.

10. The system disarms to level 1, and you will hear,





"SYSTEM IS DISARMED"

Tripping Learn Mode Wireless Sensors

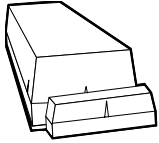
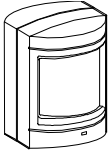
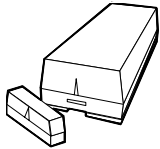
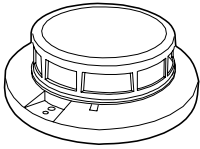
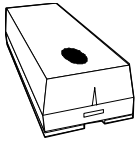
This task illustrates tripping the most common wireless sensors.

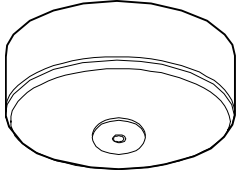
Sensor	Do This to Trip the Sensor
<p>Door/Window</p> 	<p>Open the secured door or window.</p>
<p>PIR Motion</p> 	<p>Avoid the motion detector's view for 5 minutes, then enter its view.</p>
<p>Shock</p> 	<p>Tap the glass twice, away from the sensor. Wait at least 30 seconds before testing again.</p>
<p>System Smoke</p> 	<p>Press and hold the test button until the system sounds transmission beeps.</p>
<p>Freeze</p> 	<p>Apply ice to the sensor. Do not allow the sensor to get wet.</p>

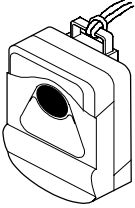
Sensor	Do This to Trip the Sensor
<p data-bbox="188 254 597 289">Rate-of-rise Heat Detector</p> 	<p data-bbox="711 254 1300 317">Rub your hands together until warm, then place one hand on the detector for 30 seconds.</p>
<p data-bbox="302 548 483 583">Glass Guard</p> 	<p data-bbox="711 548 1198 579">Tap the glass 3 or 4 inches from the sensor.</p>
<p data-bbox="266 747 519 783">Emergency Panic</p> 	<p data-bbox="711 747 1338 810">Press and hold the appropriate panic button(s) for 3 full seconds.</p>
<p data-bbox="217 1073 285 1104">NOTE</p> <p data-bbox="217 1115 646 1241">Refer to the particular sensor's installation instructions for more details on tripping Learn Mode wireless sensors.</p>	

Correcting a Failed Sensor

This task outlines how to fix a sensor when it fails the sensor test.

Use an RF Sniffer

If touchpads and/or Supervised Wireless Interior Sirens do not beep when a sensor is tripped, use an ITI RF Sniffer (60-401) test tool to verify that the sensor is transmitting.

Constant beeps from the sniffer indicate a runaway (faulty) sensor. Remove the sensor's battery and replace the sensor.

Reposition the Sensor

1. Rotate the sensor and test for improved sensor communication at 90 and 180 degrees from the original position.
2. If poor communication persists, relocate the sensor.

Relocate the Sensor

1. If possible, locate sensors within 150 feet of the panel. While a transmitter may have a range of 1,500 feet or more in the open, the environment at the installation site (for example, near wiring or metal objects) can have a significant effect on range.
2. Test the sensor a few inches from the original position.
3. Increase the distance from the original position and retest until you find an acceptable location.
4. Mount the sensor in the new location.
5. Replace the sensor if no location is acceptable.

Replace the Sensor

1. Using a sensor that you know works, test it at the same location.
2. If the transmission beeps remain below the minimum level, avoid mounting a sensor at that location.
3. If the replacement sensor functions, contact ITI for repair or replacement of the problem sensor.

Testing Telephone Communications

This task illustrates testing phone communication between the panel and the central station (CS).

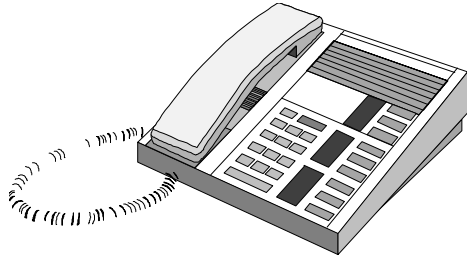

1. Inform the central station that you will be testing phone communications between the site and the CS.

2. Press **8 + System or Partition Master CODE + 2**.

The touchpad sounds one beep and the display shows:

PHONE TEST

When the panel completes the test, the system automatically returns to the previous arming level.

3. If the display shows PHONE TEST for 1½ minutes or more, enter **1 + System or Partition Master CODE** and refer to the Troubleshooting section.

Testing Central Station/Pager Communication

This task illustrates ensuring the Concord panel is correctly reporting alarms to the central station.

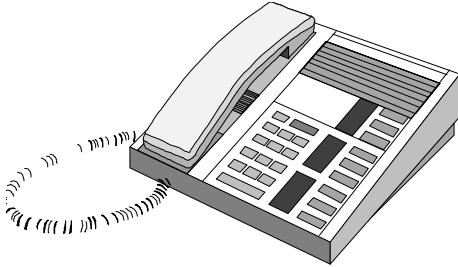

1. Make sure that all on-premises telephones are hung up (on hook).
2. Inform the central station operator that you'll be testing the communications between the Concord panel and the CS.
3. Arm the system.
4. Test each of the touchpad and wireless panic buttons and trip at least one sensor of each type (fire, intrusion, etc.).

The CS operator can listen-in and talk to you through the AVM200, if one is installed.

5. Check the pager(s) to see if received the correct report.

Pagers display an event code, sensor number, and account number when they receive a message from the Concord panel.

For example:

999-02 56789

Pager Event Code Descriptions

111 System has been disarmed
222 System has been armed to STAY
333 System has been armed to AWAY
118 Trouble condition has been cleared
119 Alarm has been canceled
555 Phone test started
888 System has a trouble condition
999 System is in alarm

6. When you finish testing the system, call the CS operator again to verify that the alarms were received correctly.

Testing Outputs

This task illustrates testing the system's outputs (onboard outputs, SnapCards, and the HOM).

1. Inform the central station (CS) operator that you will be testing the system.
2. Make sure that all on-premises telephones are hung up (on hook).
3. Activate each programmed item.
Remember to arm the system to the correct level for devices that only work in a certain level.
4. Call the CS operator again to verify that the correct alarm was received at the CS.

Testing the Light Control

This task illustrates testing the X-10 lamp modules to verify house code and light number settings.

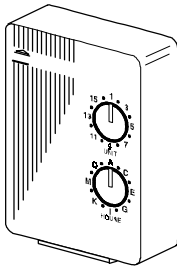

**X-10 POWERHOUSE
LAMP MODULE
13-204**

1. Press **0 + 0** on the touchpad or *** + ACCESS CODE + 0** from a telephone repeatedly to turn all lights on and off together.
2. Press **0 + 1** on the touchpad or *** + * + 1** from a telephone repeatedly to turn light 1 on and off.
3. Repeat step 2 for the remaining assigned lamp and appliance module unit numbers.
4. Press **3 + CODE** on the touchpad or *** + 3 + CODE** from a telephone to arm the system to Level 3-Away.
5. Press **1 + CODE** on the touchpad or *** + 1 + CODE** from a telephone to disarm the system.

NOTE

Unit 2 light should blink once to indicate the arming Level 1-Off. All remaining lights should be unaffected. Lights should turn on and remain on during fire and auxiliary alarms and flash during a police or an intrusion alarm.

Testing the Energy Saver Module

This task illustrates testing the Energy Saver Module (ESM) and ensuring it overrides the thermostat as programmed.

NOTE

The system must have the high- and low-temperature limits set to test the ESM.

1. Press **STATUS + STATUS** on any touchpad.

The system will tell whether the Energy Saver is on or off. For example:

ENERGY SAVER OFF
TEMPERATURE 78

The temperature displayed should match the house thermostat. If the temperatures do not match, recalibrate the ESM temperature.

2. Press **7 + 2** to turn on the ESM. The display shows:

ENERGY SAVER ON

And the ESM will click once.

3. Press **7 + 2** again to turn the ESM off. The display shows:

ENERGY SAVER OFF

Testing Exercise

Now it's your turn to practice what you've learned. Using the Concord system provided in the classroom, test the following components that you installed in the Installation and Programming Exercise.

Test the Following Items:

- Both touchpads
- The wireless sensor on the front door
- The wireless smoke sensor in the hallway
- The hardwire interior speaker.
- The Interrogator Audio Verification Module (AVM).

Module 6-Troubleshooting

Introduction

This module teaches the installer how to troubleshoot the Concord system.

What's in This Module

Basic Troubleshooting.....	6-2
Power Troubles.....	6-2
Phone Troubles	6-4
Programming Troubles.....	6-5
Wireless Device Troubles	6-6
Hardwired Device Troubles.....	6-9
Line Carrier Troubles	6-10
Normal Operation Troubles	6-11

Basic Troubleshooting

This task illustrates the basics of troubleshooting. Troubleshooting can help you eliminate system problems by methodically isolating and eliminating them.

Troubleshooting Equipment

NOTE

ITI Technical Support recommends that you use 22-gauge wire for Concord wiring.

- Voltmeter
- Butt Set
- RF Sniffer (available from ITI)
- Alphanumeric Keypad
- Appropriate Technical and Reference Manuals

Power Troubles

This troubleshooting section presents:

- Tips for preventing power troubles
- Power problems and solutions
- Flowcharts to help you solve power problems

Power Tips

- Make sure that the system is using the correct transformer.
- Make sure the transformer is not plugged into a switched outlet.
- For panel power problems, use a voltmeter to check the power between terminals 1 and 2. It should read 24 VAC.

Power Problems

Panel does not power up. Touchpads don't display or respond

1. Check that panel transformer is plugged into an unswitched outlet.
2. Check the AC circuit breaker to be sure the circuit is live.
3. Check that the backup battery is installed correctly and the AC power transformer is plugged in.
4. Check for proper panel and transformer wiring.
5. Measure the incoming AC voltage at panel terminals 1 and 2. It should read 24 VAC.
6. Check for proper installation of the Power Line Carrier Card. If PLC is not being used, verify the jumpers remain in place.

No incoming AC voltage at panel terminals 1 and 2

1. Unplug the AC power transformer and disconnect the wires from the transformer and the panel.
2. Check the transformer-to-panel wire for short or open circuits.
3. Plug in the transformer and check for 24 VAC at the transformer's unconnected terminals. If zero (0) volts, replace the transformer.

Solutions

Power Problems

Solutions

Touchpad displays *System Low Battery* or voice sounds “*System low battery.*”

1. Check that the backup battery is installed correctly and the AC power transformer is plugged in.
2. Measure the incoming AC voltage at the panel terminals 1 and 2. It should read 24 VAC.

NOTE

When the panel is running a backup battery test, the reading at the connected battery can range from 11.2 to 13.5 VDC. The panel automatically runs a backup battery test under the following conditions: (1) on initial power-up, (2) during sensor test, (3) once every minute when backup battery has failed, (4) once every 24 hours at the programmed STIME (UL 98 Options off) or once every 4 hours (UL 98 Options on).

NOTE

With the AC power transformer plugged in, the panel automatically charges the battery. While the battery is charging for the first time it is normal for the system to indicate *System battery failure*. This can take a number of hours depending on the battery's initial charge. Once the battery reaches 12.5 VDC (full charge as measured while in battery test), the condition clears. If the trouble condition persists after 24 hours, replace the backup battery.

After pressing **STATUS** the touchpad indicates *AC Power Failure*. (Panel continues to operate from backup battery.)

1. Check the AC circuit breaker to be sure the circuit is live.
2. Check for proper panel and transformer wiring.
3. Check that the transformer is plugged into an unswitched outlet and secured with the provided screw.
4. Check that the transformer is supplying AC to the panel. (Transformer internal fuse may be blown.)

WARNING

Be careful when securing the transformer to an outlet with a metal cover. Hold the cover tightly in place. You could receive a serious shock if the metal outlet cover drops down onto the prongs of the plug while you are securing the transformer and cover to the outlet box.

Touchpad displays, “Sensor # trouble and/or Sensor # low battery.”

Replace the sensor battery.

Phone Troubles

- Tips for preventing phone troubles
- Phone problems and solutions
- Flowcharts to help you solve phone problems

Phone Tips

Tips

- Review the wiring diagram.
- Make sure the panel is wired ahead of the other telephones on the line.
- Sometimes fax machines, modems and similar devices affect communication with the central monitoring station.
- Voice mail and roll-over lines also affect remote access. If one of these features exist, isolate the phone line so the panel is the only equipment using it and test communications.

Phone Problems

Solutions

System does not seize phone line

Check the wiring.

Phone voltage won't clear

Check the line voltage. It should be 42.75 to 53.0 volts **on hook** and about 10 volts **off hook**.

System not sending signals to Central Station

Make sure the Central Station phone number is programmed correctly.

Loss of dial tone on premises phones after wiring the RJ-31X/CA-38A (phone) Jack or connecting the DB-8 (phone) Cord

1. Wait 2 minutes and try again. The panel may be busy trying to report to the central station.
2. Disconnect the panel DB-8 cord from the RJ-31 jack. If the phone still doesn't work, the system is okay and the problem is in the wiring.
3. Check RJ-31X jack wiring and TELCO block wiring. Replace RJ- 31X jack if necessary.
4. Check DB-8 cord connections at the panel and RJ-31X jack. Replace cord if necessary.
5. Perform a phone test after troubleshooting the phone line.

Constant dial tone, preventing dial-out on premises phones

One or more polarity-sensitive phones exist on-site. Reverse the phone wires connected to the brown and gray wire terminals on the RJ-31X jack.

Phone does not work.

Disconnect the panel DB-8 Cord from the RJ-31 Jack. If the phone still doesn't work, the system is OK and the problem is in the phone wiring.

Programming Troubles

- Tips for preventing programming troubles
- Programming problems and solutions
- Flowcharts to help you solve programming problems

Programming Tips

Tips

- Review the programming module.
- Test the panel before installing it.
- Bring an alphanumeric keypad to the site.

Programming Problems

Solutions

Wireless sensors and devices won't respond

If the Concord panel is the Hybrid, SuperBus Wireless Receiver must be properly installed. Check the wiring and make sure the unit number is correct.

Alphanumeric touchpad won't respond.

- Alphanumeric touchpads must be part numbers 60-746 or 60-728.
- Repeat the procedures for adding the touchpads. See the *Concord Security System Reference Manual* or
- See Concord Programming Training Module - Verifying Alphanumeric Touchpad Unit Numbers.

Wireless Device Troubles

- Tips for preventing wireless device troubles
- Wireless device problems and solutions
- Flowcharts to help you solve wireless device problems

Wireless Device Tips

- Conduct a sensor test (**8** + **access code** + **3**, then trip the sensors).
- Sensor Conditions
 - Supervisory
 - Trouble
 - Failure
 - Open
- If a sensor does not check in during the dealer sensor test, check the sensor battery or you may need a repeater.
- Duct work, concrete, and steel affect the panel's ability to hear a wireless device.
- Repositioning wireless devices may improve reception.

Wireless Device Problems

Solutions

Not checking in

- Make sure the environment around the sensor isn't interfering with the signal. See the sensor's installation instructions for tips about placement of the sensor.
- Make sure the sensor is programmed into the proper group.

Won't Bypass Sensor(s)

1. Sensor is already bypassed.
2. Attempting to bypass a 24-hour sensor that cannot be bypassed (group 26 fire sensors).
3. Sensor that is not active in the current arming level.
4. Review the procedures for bypassing a sensor.
5. See Bypassing Window or Door Sensors in the Concord System Operation Training Module or see the bypassing instructions in the Concord Security and Home Automation Owner's Manual.

Alarm for no reason	<ul style="list-style-type: none"> • Smoke sensors <ul style="list-style-type: none"> - Check for dirty chamber • Motion detectors: <ul style="list-style-type: none"> - Direct sunlight can cause false alarms - Heating/AC vents can cause false alarms - Plants and curtains that move cause false alarms. • Door/Window Sensor <ul style="list-style-type: none"> - Check the magnet spacing and for loose doors or windows at all door/window sensor locations.
Smoke sensor beeps once every minute	Batteries are low. Replace all of the smoke sensor batteries.
Difficulty learning wireless sensor with HW contact	The contact must be in the alarm state. (open if normally closed, close if normally open). If this isn't set up correctly, the sensor will be learned in backwards.
Grouping issues and explanations	<ul style="list-style-type: none"> • For more information on sensor groups, see the following references: <ul style="list-style-type: none"> - Appendix C of the Concord Security System Installation Manual - Concord Programming Training Module
Hardwired sensors showing open state	The sensor may be learned in backwards. The contact must be in the alarm state. (open if normally closed, closed if normally open).
Difficulties learning in hard-wired devices	<p>CAUTION</p> <p>Remove wiring for hardwire loop. Wire a 2k ohm resistor across the terminals.</p> <p>Complete the procedure for learning sensors (See Learning Sensors in the Concord Programming Training Module or see Adding Hardwire Sensors in the Concord Security System Reference Manual.</p> <p>Normally Open Sensors</p> <p>Follow the procedure and when you are prompted to trip sensors – short across terminals.</p> <p>Normally Closed Sensors</p> <p>Follow the procedure and when you are prompted to trip sensors – pull one leg of resistor out of terminal.</p> <p>Rewire hardwire sensor (include one 2k ohm resistor).</p>

CONCORD Troubleshooting

Hardwire Smoke Sensor

NOTE

This "double disarm" procedure restores the hardwired smoke sensors to their normal condition.

1. Enter access **1 + CODE** to disarm panel.
2. Enter **1 + CODE** again to temporarily cut power to hardwired smoke sensors.

Receiver failure

Check the wiring from the panel to the receiver.

Runaway Wireless Sensor

- Sensor continuously transmitting
- Sensor blocks transmissions from other sensors
- Panel won't respond
- All other sensors send supervisory reports to monitoring company

Use an RF sniffer to determine if the sensor is continuously transmitting.

Panel doesn't respond to sensor activity (no alarm, chime, or sensor test sounds)

1. Check that the wireless sensor battery is installed.
2. Check the sensor battery for low voltage. Replace batteries, if necessary.
3. Use an RF Sniffer (60-401) to verify that sensor is transmitting.
4. Check that the sensor is programmed (learned) into panel memory. Learn the sensor, if necessary.
5. Verify panel/receiver antennas are installed and connections tight.

Panel doesn't respond to wireless touchpad commands

1. Operate touchpads from different locations to locate areas of intermittent operation.
2. Check and/or replace wireless touchpad battery.
3. Program or reprogram the touchpad(s) into the panel.

Hardwired Device Troubles

- Tips for preventing hardwired device troubles
- Hardwired device problems and solutions
- Flowcharts to help you solve hardwired device problems

Hardwired Problems

Solutions

Hardwired Device Tips

- Review the wiring diagram.
- Avoid running wires parallel to electrical lines or near fluorescent lights.
- Check for hardwired zone problems, use a voltmeter to check the power between terminals **zone** and **ground**:
power on - 5 VDC, power off - 0 VDC.

Panel does not respond to hardwire zone input

NOTE

Panel hardwire zones are ignored for 1 minute following power-up (HIM zones are not ignored for this period).

1. Check that zones are programmed into panel and add if missing.
2. Make sure that zone is in a restoral-required group or make sure that system is armed to active level before tripping sensor.
3. If optional HIM zone, check that the HIM LED is blinking to show communication with panel.

Touchpad displays, “[sensor #], trouble” and/or “Sensor [sensor #] trouble,” is heard.

NOTE

Panel zones use a 2K ohm resistor. Snapcard use a 2K ohm resistor. HIM zones use 4.7K ohm resistor.

1. Check that the end-of-line resistor is correctly installed in the zone loop circuit.
2. Check normally open (N/O - parallel) zone circuit for a short in the wires.
3. Check normally closed (N/C - series) zone circuit for an open (break) in the wires.

Hardwire zones will not learn into the panel

1. Verify wiring on zone 8. If the two-wire smoke loop option is off, zone 8 will be connected to terminals 20 and 22. If the two-wire smoke loop is on, zone 8 will be connected to terminals 22 and 23.
2. Verify the HIM LED is blinking to indicate Bus communication.

Line Carrier Troubles

- Tips for preventing line carrier troubles
- Line carrier problems and solutions
- Flowcharts to help you solve line carrier problems

Line Carrier Tips

- Most line carrier troubles involve incorrect settings of the X-10 module or the Supervised Wireless Interior Siren (SWIS).
- Noise (spikes) on AC lines is often caused by appliances on the line (examples: refrigerators, microwaves, TV, etc.) When someone turns on one of those devices, the line carrier device may sound.
- Review the device's installation instructions.

Line Carrier Problems

Solutions

Line Carrier sounds intermittently

Noise on an AC line may cause a line carrier device to sound without reason. Relocate the device or the appliance to another circuit.

SWIS won't stop sounding when disarmed

You may need to disarm the system more than once to quiet the SWIS.

SWIS Battery chirps

The backup battery is low, replace it.

SWIS doesn't work correctly

Set the SWIS dip switches correctly. See *Installing the SWIS Battery and Setting the DIP Switches* in Chapter 2 – *Installing the System of the Concord Security System Reference Manual*.

X-10 doesn't work

Make sure the Power Line Carrier Card is installed correctly. See the *Concord Security System Reference Manual*

X-10 doesn't work correctly

Make sure the correct unit number is set.

Light fixtures controlled by the X-10 Lamp Module are not working

1. Check that the lamp has a working bulb and that the lamp switch is on.
2. Confirm the lamp's operation at a working outlet.
3. Check that the lamps are plugged into X-10 Lamp Modules and the X-10 Lamp Modules are plugged into outlets that are not controlled by a switch. Relocate to non-switched outlets, if necessary.
4. Check that the panel is powered by the special two-wire Class II Line Carrier Power Transformer.
5. Make sure the panel has the Power Line Carrier (PLC) card installed.
6. Check that the HOUSE dial on the X-10 Lamp Module matches the house code programmed into the panel.

Normal Operation Troubles

- Tips for preventing normal operation troubles
- Normal operation problems and solutions
- Flowcharts to help you solve normal operation problems

Normal Operation Tips

- Review the device's installation instructions.

Normal Operation Problems

Solutions

System won't arm

1. Wrong access code
2. If arming to level 2, make sure all monitored perimeter doors and windows are closed.
3. If arming to level 3, make sure all perimeter and interior sensors are closed.
4. Press **STATUS** for an indication of the problem.

Duress code isn't working

1. Make sure the code is correct.
2. Make sure that the duress option is on.

Trouble beeps from panel

Press **STATUS** for an indication of the problem.

CONCORD
Troubleshooting

Module 7-System Operation

Introduction

This module teaches the installer how to use the basic features of the Concord system after it is installed and programmed.

What's in This Module

Basic System Commands	7-2
Arming the System.....	7-4
Disarming the System	7-7
Bypassing Window or Door Sensors.....	7-8
Sending Panic Alarms.....	7-10
Checking System Status.....	7-13
Understanding Access Codes.....	7-14
Deleting a Regular User Access Code.....	7-15

Basic System Commands

These tables include the most commonly used system commands for quick reference.

TABLE 7-1. Touchpad Commands.

System Response	Command
Indicates system's current status	* (STATUS)
Disarms partition to OFF	1 + CODE
Arms partition to STAY	2 + CODE
Arms partition to AWAY	3 + CODE
Arms partition to STAY	2 (quick arm on)
Arms partition to AWAY	3 (quick arm on)
Makes partition entry/exit doors instant (4 must be pressed within five seconds of arming)	2 or 3 + CODE + 4 or 2 or 3 + 4
Arms partition silently (no arming status beeps)	5 + 2 or 3 + CODE or 5 + 2 or 3
Arms partition with Latchkey feature enabled	2 or 3 + CODE + 6 or 2 or 3 + 6
Turns chime feature on and off	7 + 1
Turns energy saver on and off	7 + 2
Identifies alarms in memory	7 + 6
Initiates a phone test	8 + CODE + 2
Initiates a sensor test	8 + CODE + 3
Initiates a dealer sensor test	8 + installer CODE + 3
Turns all lights on and off	0 + 0
Turns selected light on and off	0 + n (1 through 9)

TABLE 7-2. Touchtone Phone Commands.

System Response	Command
Indicates system's current status	# + *
Disarms partition to OFF	# + 1 + CODE
Arms partition to STAY	# + 2 + CODE
Arms partition to AWAY	# + 3 + CODE
Arms partition to STAY	# + 2 (quick arm on)
Arms partition to AWAY	# + 3 (quick arm on)
Makes partition entry/exit doors instant (4 must be pressed within five seconds of arming)	# + 2 or 3 + CODE + 4 or # + 2 or 3 + 4
Arms partition silently (no arming status beeps)	# + 5 + 2 or 3 + CODE or # + 5 + 2 or 3
Arms partition with Latchkey feature enabled	# + 2 or 3 + CODE + 6 or # + 2 or 3 + 6
Turns chime feature on and off	# + 7 + 1
Turns energy saver on and off	# + 7 + 2
Disables system access from on-site phones	# + 7 + 3
Identifies alarms in memory	# + 7 + 6
Initiates a phone test	# + 8 + CODE + 2
Initiates a sensor test	# + 8 + CODE + 3
Initiates a dealer sensor test	# + 8 + installer CODE + 3
Turns all lights on and off	# + 0 + 0
Turns selected light on and off	# + 0 + n (1 through 9)

Arming the System

This task illustrates arming the system to levels two and three from a touchpad, a telephone, and a keychain touchpad.

Arming the System: Touchpad



Arming to Level 2 - Stay or 3 - Away

Use **Level 2 - Stay** when the homeowner is in the home and wants security turned on.

Use **Level 3 - Away** when the homeowner will be off the premises.

NOTE

If the Quick Arm feature is turned on by the programmer, the user can choose the arming level without entering the code.

1. Enter **2** for stay, or **3** for away.

ENTER CODE

2. Enter the **access code**.

The touchpad will display:

ARMED TO STAY

or

ARMED TO AWAY

3. You will hear:



TWO OR THREE SHORT BEEPS.

During the delay period you will hear three series of beeps.

During the first series, you will hear one beep every 4 or 5 seconds (how long this lasts depends on the entry/exit delay setting).

The second series of beeps contains 10 quick beeps at the end of the delay period.

Finally, you'll hear two or three fast beeps confirming that the system is in Stay (2) or Away (3).

NOTE

If an alarm sounds, cancel it by entering the
1 + access code.

4. Additional options:

- To cancel the exit delay, press **4** within 5 seconds.

The touchpad will display:

ARMED TO STAY NO DELAY

or

ARMED TO AWAY NO DELAY

Arming the System: On-Site Telephone

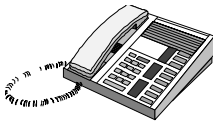

NOTE

Concord uses **#** as the lead character for telephone access. It can be programmed to use ***** as the lead character.

Arming to Level 2 - Stay or 3 - Away

Use **Level 2 - Stay** when the homeowner is in the home and wants security turned on.

Use **Level 3 - Away** when the homeowner will be off the premises.

1. Enter **# + (2 or 3) + your access code**.

(If dialing from an off-site location, dial the phone number before entering **# + your access code**.)

You will hear:



TWO OR THREE SHORT BEEPS, THEN "SYSTEM IS ARMED TO (STAY OR AWAY)."

2. Additional options:

- To cancel the exit delay, press **4** within 5 seconds.

3. If entering or exiting, do so during the delay period or an alarm will sound.

During the delay period you will hear three series of beeps.

During the first series, you will hear one beep every 4 or 5 seconds (how long this lasts depends on the entry/exit delay setting).

The second series of beeps contains 10 quick beeps at the end of the delay period.

Finally, you'll hear two or three fast beeps confirming that the system is in Stay (2) or Away (3).

Arming the System: Keychain Touchpad

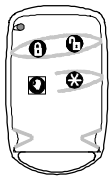

1. Press and hold the **Lock** button until the keychain light blinks.

2. If anyone is exiting, do so during the exit delay period. An alarm will sound if you exit after the delay period is over.

You will hear one beep every 4 seconds for most of the delay, then one beep every second for the last 10 seconds of the delay.

Two short beeps indicate the end of the exit delay.



3. If the keychain is programmed to do so, you can cancel the delay by pressing the **Star** button until the keychain entry/exit light blinks.

Disarming the System

This task illustrates disarming the system from a touchpad, telephone, and keychain touchpad.

Disarming the System: Touchpad



Disarming the system places it in **Level 1 - Off**. That means that protection to doors, windows, and motion devices is turned off.

However, smoke detectors and police, fire, and auxiliary panic alarms are still on.

1. Enter **1** + the **access code**.

The touchpad will display the date and time

2. You will hear:



ONE LONG BEEP.

Disarming the System: Telephone

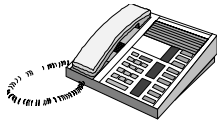

Disarming the system places it in **Level 1 - Off**. That means that protection to doors, windows, and motion devices is turned off.

However, smoke detectors and police, fire, and auxiliary panic alarms are still on.

1. Enter **# + 1** + your **access code**.

(If dialing from an off-site location, dial the phone number before entering **# + your access code**.)

Disarming the System: Keychain Touchpad

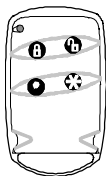

Disarming the system places it in **Level 1 - Off**. That means that protection to doors, windows, and motion devices is turned off.

However, smoke detectors and police, fire, and auxiliary panic alarms are still on.

Press and hold the **Unlock** button until the keychain light blinks.



Bypassing Window or Door Sensors

This task illustrates two ways to arm the Concord system and make it ignore certain sensors. For example, use this task when you want to arm the system while a window is open (indirect) or when you want to arm the system, then use a certain door without tripping an alarm (direct).

You can only bypass sensors using the touchpad or a telephone. The keychain touchpad cannot directly bypass sensors, but it can be used to indirectly bypass sensors.

Directly Bypassing a Sensor: Touchpad



NOTE

When you directly bypass a sensor, you must use the primary access code only. Indirect bypassing allows you to use any access code.

NOTE

In this procedure, *nn* represents the sensor number being bypassed.

Indirectly Bypassing a Sensor: Touchpad



NOTE

In this procedure, *nn* represents the sensor number being bypassed.

Directly Bypassing a Sensor: Telephone

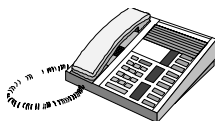

NOTE

In this procedure, *nn* represents the sensor number being bypassed.

Example: Use the *direct* method when the system is armed and you want to open a specific window while the system stays armed.

With the system armed, enter **BYPASS + access code + nn**.

The touchpad will display:

BYPASSED

Example: Use the *indirect* method when the system is unarmed, you already have an upstairs window open, and you want to arm the system.

1. With the door or window(s) open that you want to bypass, enter the **access code + 2 or 3**.

(Enter 2 to arm to Level 2 - Stay or 3 to arm to Level 3 - Away.)

2. Press **BYPASS**.

The touchpad will display:

SENSOR NN BYPASSED

Example: Use the *direct* method when the system is armed and you want to open a specific window.

With the system armed, enter **# + the access code + 6 + nn**.

Indirectly Bypassing a Sensor: Telephone

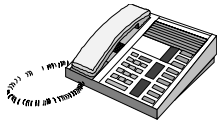

NOTE

Use the indirect method when the door or window you want to bypass is already open.

1. Enter **# + 2** or **3** the **access code**.
(Enter 2 to arm to Level 2 - Stay or 3 to arm to Level 3 - Away.)

2. You will hear:



PROTEST BEEPS.

3. Press the **# + #** buttons.

You will hear:



"*SENSOR NN BYPASSED.*"

Sending Panic Alarms

This task illustrates sending a panic alarm using a touchpad, telephone, or a keychain touchpad. Use a panic alarm to alert the central monitoring station to an emergency.

The system can send one of three panic alarms: *police*, *fire*, or *auxiliary*.

The *police* panic is a steady siren sound. The *fire* panic sounds a temporal 3. An *auxiliary* panic is a fast on-off siren sound.

Sending a Panic: Touchpad



Press the appropriate panic button: **POLICE**, **FIRE**, or **AUXILIARY** for 2 full seconds.

The touchpad will display:

POLICE ALARM

or

FIRE ALARM

or

AUXILIARY ALARM

Canceling a Panic



1. Within 15 seconds of activating a police or auxiliary alarm, enter the **1 + access code** (No call is sent to the central monitoring station.)

The touchpad will display:

1-OFF REPORT CANCELED

NOTE

Entering the **1 + access code** after a fire alarm only turns off the sirens. It does not cancel the alarm.

You will hear:



ONE LONG BEEP, THEN "ALARM SYSTEM IS OFF." IF CANCELED, "ALARM BYPASSED."

2. If 15 seconds have already passed or **if the alarm was a fire alarm**, call the central monitoring station to cancel the alarm.

Sending a Police Panic: Telephone

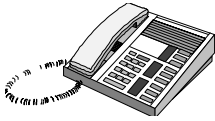

1. Press **#**.
2. You will hear a steady alarm sound.

NOTE

The telephone can only send a police panic. It cannot send a fire or auxiliary panic.

When sending a panic alarm, don't wait more than 1 second between key presses.

Canceling a Police Panic

Within 15 seconds of activating a police panic, enter **# + 1 + the access code**. (No call is sent to the central monitoring station.)

You will hear:



"ALARM SYSTEM IS OFF." IF CANCELED, "ALARM BYPASSED."

Sending a Police Panic: Keychain Touchpad

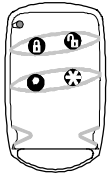

1. Using a 2- button or 4-button keychain touchpad, press and hold the **Unlock** and **Lock** buttons together until the light blinks.
2. If within range of a speaker, you will hear:



A LOUD STEADY ALARM.

Sending an Auxiliary Panic from a 4-Button Keychain

1. Press and hold the **Star** and **Lights** buttons together until the light blinks.
2. If within range of a speaker, you will hear:



A LOUD RAPIDLY BEEPING ALARM.

Canceling a Police or Auxiliary Panic

1. Within 15 seconds of activating a police or auxiliary alarm, enter the **Unlock** button. (No call is sent to the central monitoring station.)

If within range of a speaker, you will hear:



ONE LONG BEEP, THEN "ALARM SYSTEM IS OFF." IF CANCELED, "ALARM BYPASSED."

2. If 15 seconds have already passed call the central monitoring station to cancel the alarm.

Checking System Status

This task illustrates performing a short system status check. To perform a sensor test, see Module 5 – Testing the System.

Checking System Status: Touchpad



Press the **STATUS** button.

The touchpad will display:

SYSTEM OK

or any system troubles, or any recent alarms.

You will hear:



ONE, TWO, OR THREE SHORT BEEPS INDICATING
THE CURRENT ARMING LEVEL.

Checking System Status: Telephone

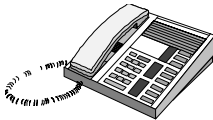

Short Status Check

Press **# + #**.

You will hear:



THE ARMING LEVEL (1-OFF, 2-STAY, OR 3-AWAY)
AND ANY SYSTEM TROUBLES

or

Any recent alarms.

Understanding Access Codes

This task provides a brief overview of the Concord system access codes. The system uses three types of codes: **System Master Code**, **Partition Master Codes**, and **Regular User Codes**. The primary access code is the main code for the system. Use it to control all functions and user programming of the system.

The System Master Code:

The system master code allows you to:

- Change or delete the partition master codes
- Add, change, and delete regular user codes

Partition Master Codes

The partition master code allows you to:

- Perform user functions, including: arming and disarming within a partition
- Change or delete the partition master code in the authorized partition
- Add, change, and delete regular user codes

Regular User Codes

The system allows up to 60 regular user codes that can be used only to arm and disarm the system. Delete additional codes when they are no longer needed.

Adding or Changing an Access Code

This task illustrates adding or changing a regular user access code, a partition master code, or the system master code (if you are authorized).



1. Enter user programming by pressing **9 + System or Partition Master CODE**.
2. Press **B** until the touchpad displays.

USER CODES

3. Press **#**.
4. Press **B** until the touchpad displays the type of code you want to change.
5. Press **#**.
6. Press **B** to scroll to the code you want to program.
7. Enter the new code and press **#**.
8. Press **B** to move to another code or press *** + 7 + #** to exit user programming.

NOTE

The system will not accept the same code for more than one user.

Deleting a Regular User Access Code

This task illustrates deleting a regular user access code. You cannot delete a partition or master code. Instead, change it to a new code when necessary.

When a code is deleted, it appears as four asterisks on alphanumeric touchpads.



1. Enter user programming by pressing **9 + System or Partition Master CODE**.

2. Press **B** until the touchpad displays.

USER CODES

3. Press **#**.
4. Press **B** until the touchpad displays the type of code you want to remove.
5. Press **#**.
6. Press **B** to scroll to the code you want to delete.
7. Enter the system master or partition code and press **#**.

The touchpad displays:

USER 01 -- * * * *

8. Press **B** to move to another code or press *** + 7 + #** to exit user programming.

CONCORD
System Operation

Module 8-End-User Training

Introduction

This module teaches the installer how to teach the homeowner to use the Concord system.

Rehearse the script with a coworker before you use it to teach a customer. That way, you'll be familiar with the script.

Read and follow the script that applies to the customer. For example, if the customer doesn't have a keychain touchpad, don't use that part of the script.

The script is shown in two columns: **Read This** and **Do This**. Read the script in the **Read This** column to the customer. Perform the steps in the **Do This** column.

The tasks are in a "demonstration and practice" style. Demonstration and practice is one of the best ways to teach people.

Each task begins with you demonstrating the steps to the customer and ends with you helping the customer perform the steps by themselves.

What You Need to Know to Operate Your System

User Programming Menu.....	8-2
Arming and Disarming the System.....	8-4
Bypassing Window or Door Sensors.....	8-9
Checking the System Status.....	8-11
End-User Training Exercise.....	8-13

User Programming Menu

The figure below illustrates the User Programming menu, which you might find useful as you navigating through the menu. Shortcut numbers appear for each item

To enter the Programming Menu, press

[9] + System Master or Partition Master Code

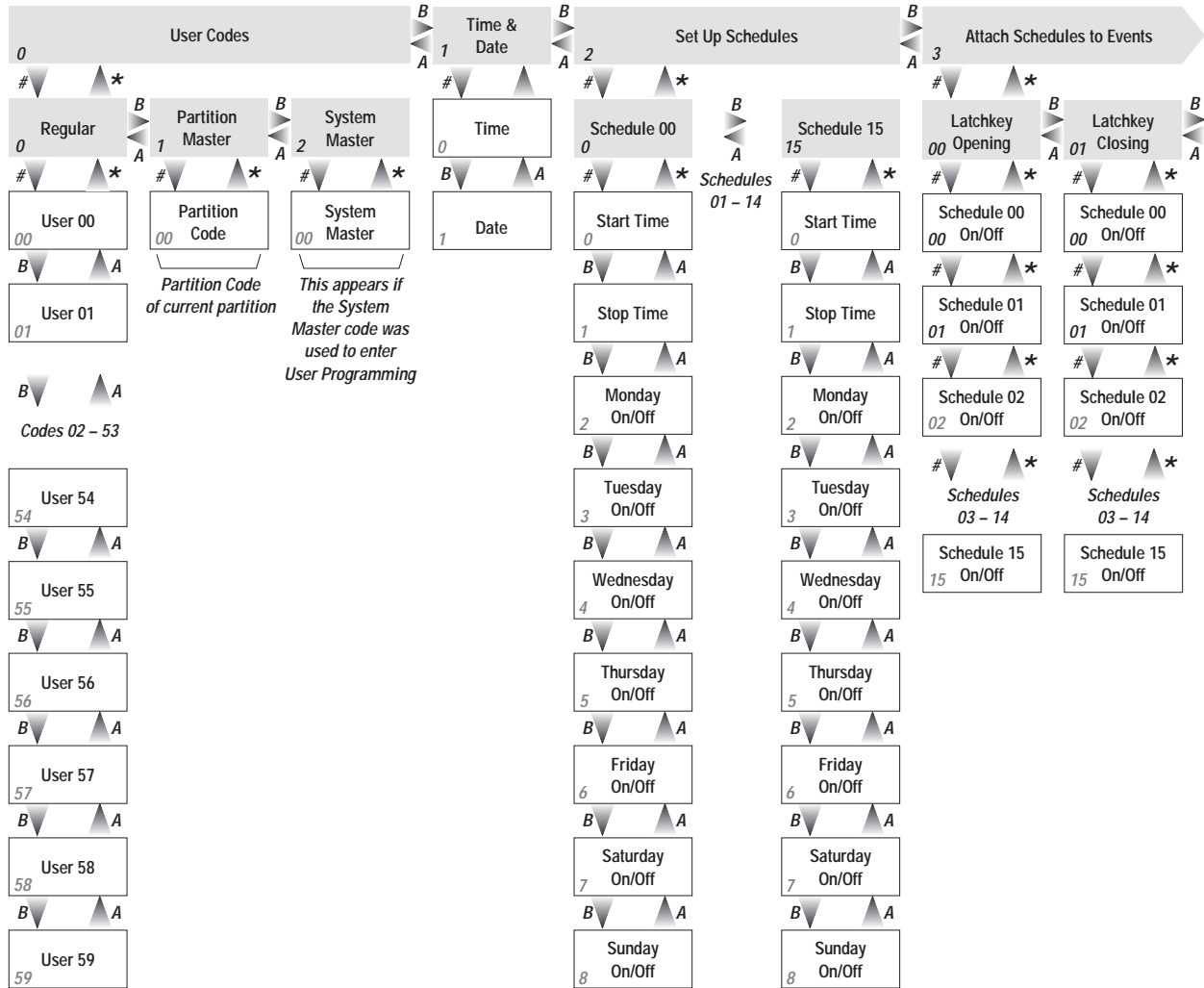

User Programming Menu – Continued

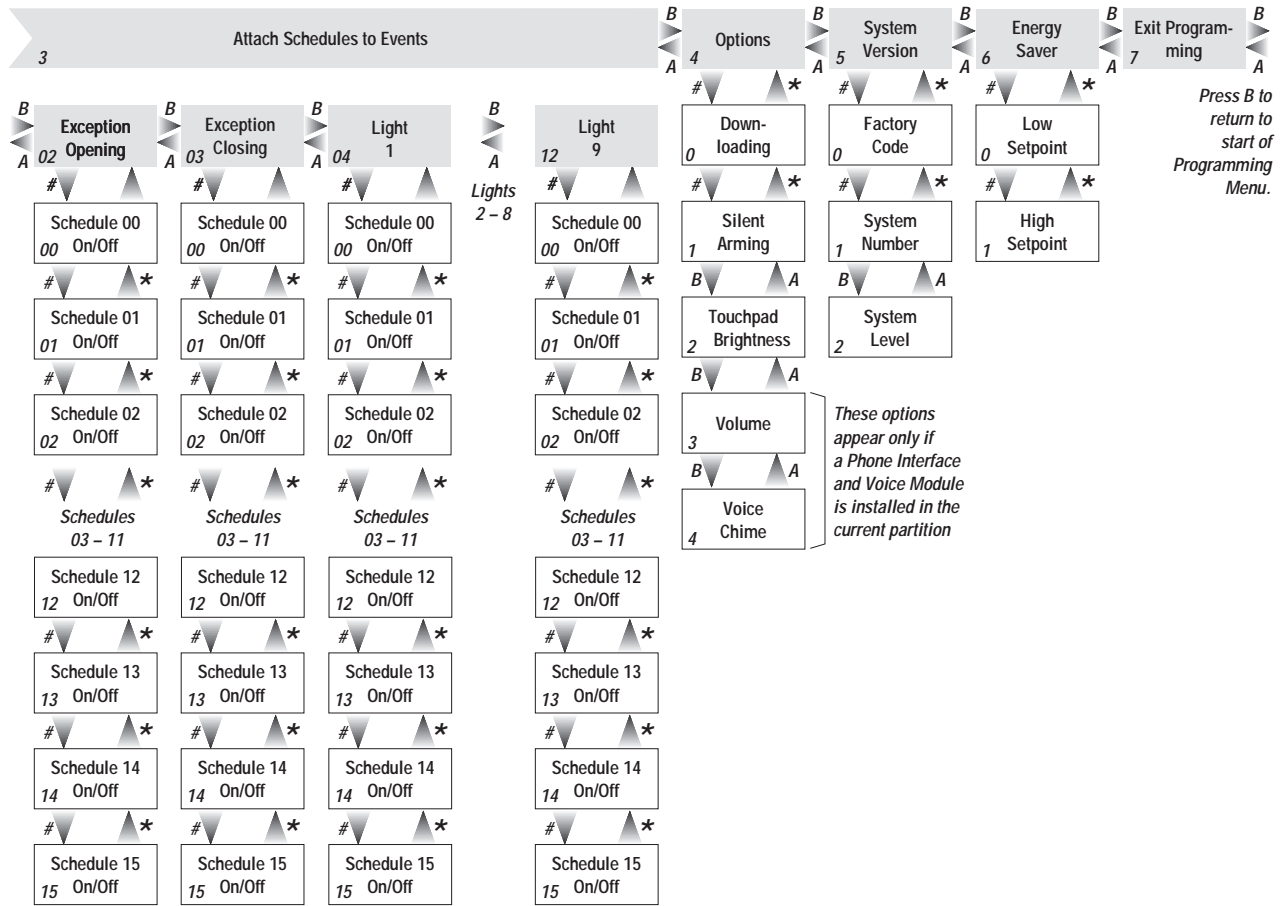

Arming and Disarming the System

This task guides you through teaching the end user how to arm and disarm the system from a touchpad, telephone, and a keychain touchpad to Level 2 or 3.

Touchpad: Arming and Disarming the System



Read This	Do This
<p>“I’m going to show you how to arm your Concord security system using a touchpad.”</p> <p>“First, I’ll arm the system to Level 2 - Stay.”</p> <p>“Use Level 2 when the homeowner is in the home and wants security turned on.”</p>	<p>1. Tell the customer what you are entering as you enter the 2 + access code.</p>
<p>“Notice that the touchpad displays, ‘2-STAY’ and the speaker gives two short beeps and says, ‘Alarm system is on Level 2.’”</p>	<p>2. Show the customer the display.</p>
<p>“If you want to turn off lights, press 0 within 5 seconds.”</p>	<p>3. Tell the customer what you are doing as you press 0 within 5 seconds.</p>
<p>“Now, I’ll show you how to disarm the system.”</p> <p>“Disarming the system places it in Level 1 - Off. That means that protection to doors, windows, and motion devices is turned off.”</p> <p>“This is also how you turn off the system if you accidentally set off the alarm.”</p> <p>“However, smoke detectors and police, fire, and auxiliary panic alarms are still on.”</p>	<p>4. Tell the customer what you are entering as you enter the 1 + access code.</p>
<p>“The touchpad displays ‘1-OFF.’”</p> <p>“The speaker gives one long beep, then says, ‘Alarm system is off.’”</p>	<p>5. Show the customer the display.</p>

<p>“Now it’s your turn to arm the system. I’m going to tell you how to arm the system to Level 3 - Away while you push the buttons.”</p> <p>“Use Level 3 - Away, when you will be out of the house.”</p> <p>“Press 3 and enter your access code.”</p>	<p>6. Watch and assist the customer.</p>
<p>“Notice that the display showed, ‘ARMED TO AWAY’ and the speaker sounded three beeps.”</p> <p>“You must enter and exit during the exit delay or the alarm will sound.”</p> <p>“You’ll hear one beep every 4 seconds for most of the delay, then one beep every second for the last 10 seconds of the delay.”</p> <p>“If you want to cancel the exit delay, press 4 within 5 seconds after entering the alarm level.”</p> <p>“If you do, the display will show, ‘ARMED TO AWAY NO DELAY’ and the speaker will say, ‘No delay.’”</p>	<p>7. Show the display to the customer.</p>
<p>“If an alarm sounds, you can cancel it by entering your 1 + access code.”</p> <p>“Then see the help box.”</p> <p>“Now I’ll tell you how to disarm the system.”</p> <p>“Press your access code - then press 1.”</p>	<p>8. Watch and assist the customer.</p>
<p>“Note the display shows the date and time and you hear one long beep.”</p>	<p>9. Show the display to the customer.</p>
<p>“Remember that disarming the system places it in Level 1 - Off. Protection to doors, windows, and motion devices is turned off.”</p> <p>“Smoke detectors and police, fire, and auxiliary panic alarms are still on.”</p>	

Telephone: Arming and Disarming the System

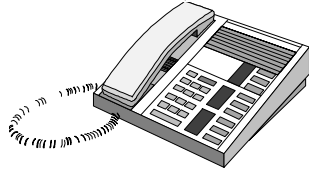

NOTE

Use the phone to control the system only if a Phone Interface/Voice Module is installed.

Read This	Do This
<p>“I’m going to show you how to arm your Concord security system using a telephone.”</p> <p>“First, I’ll arm the system to Level 2 - Stay.”</p> <p>“Use Level 2 when the you are in the home and want security turned on.”</p>	
<p>“The telephone says, ‘System is armed to STAY’ and you’ll hear two short beeps.”</p> <p>“Also notice that I press the # button first. That tells the system that you’re going to enter a command for the security system instead of dialing a phone call.”</p>	<p>1. Allow the customer to listen if possible using speaker phone. Enter # + 1 + the access code.</p>
<p>“If you want to turn off the lights, press 0 within 5 seconds.”</p>	<p>2. Tell the customer what you are entering as you press 0 within 5 seconds.</p>
<p>“Now, I’ll show you how to disarm the system using the telephone.”</p> <p>“Disarming the system places it in Level 1 - Off. That means that protection to doors, windows, and motion devices is turned off.”</p> <p>“This is also how you turn off the system if you accidentally set off the alarm.”</p> <p>“However, smoke detectors and police, fire, and auxiliary panic alarms are still on.”</p>	<p>3. Tell the customer what you are doing as you enter # + 1 + the access code.</p>
<p>“The telephone says, ‘Alarm system is off.’”</p>	<p>4. Allow the customer to listen, if possible, using speaker phone.</p>

<p>“Now it’s your turn to arm the system. I’m going to tell you how to arm the system to Level 3 - Away while you push the buttons.”</p> <p>“Use Level 3 - Away, when you will be out of the house.”</p> <p>“press 3 and your access code to arm to the away mode.”</p>	<p>5. Watch and assist the customer.</p>
<p>“Notice that the phone said, ‘Alarm system is on level 3.’”</p> <p>“If you want to cancel the exit delay, press, press 4 within 5 seconds.”</p> <p>“If you do, the telephone will say, ‘No delay.’”</p> <p>“You must enter and exit during the entry/ exit delay or the alarm will sound.”</p> <p>“If you are near a speaker, you’ll hear one beep every 4 seconds for most of the delay, then one beep every second for the last 10 seconds of the delay.”</p> <p>“If an alarm sounds, you can cancel it by entering your # + 1 + your access code.”</p> <p>“Now I’ll tell you how to disarm the system.”</p> <p>“Press # + 1 + your access code.”</p>	<p>6. Watch and assist the customer.</p>
<p>“Notice that the telephone says, ‘Alarm system is off.’”</p> <p>“Remember that disarming the system places it in Level 1 - Off. Protection to doors, windows, and motion devices is turned off.”</p> <p>“Smoke detectors and police, fire, and auxiliary panic alarms are still on.”</p>	

Keychain Touchpad: Arming and Disarming the System

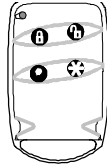

Read This	Do This
<p>“I’m going to show you how to arm your Concord security system using a keychain touchpad.”</p> <p>“First, I’ll arm the system to level that it is programmed.”</p>	<p>1. Show and tell the customer what you are entering as you press and hold the LOCK button until the keychain light blinks.</p>
<p>“If you are within range of a speaker, you will hear two or three short beeps, then the system will announce, ‘System is armed to (STAY or AWAY).’”</p> <p>“If you want to turn to turn off lights, press Lights button.”</p>	<p>2. Show and tell the customer as you press the Lights button.</p>
<p>“Now, I’ll show you how to disarm the system using the keychain touchpad.”</p> <p>“Disarming the system places it in Level 1 - Off. Therefore, protection to doors, windows, and motion devices is turned off.”</p> <p>“This is also how you turn off the system if you accidentally set off the alarm.”</p> <p>“However, smoke detectors and police, fire, and auxiliary panic alarms are still on.”</p>	<p>3. Tell the customer what you are doing as you press and hold the Unlock button until the light on the keychain blinks.</p>
<p>“If you are within range of a speaker, you will hear one beep that means the system is disarmed to level one.”</p> <p>“Now it’s your turn to arm the system. I’m going to tell you how.”</p> <p>“Press and hold the Lock button until the light on the keychain blinks.”</p>	<p>4. Point to the Lock button, if necessary.</p>
<p>“If you are within range of a speaker, it will announce, ‘System is armed to (STAY or AWAY).’”</p> <p>“Now, I’ll tell you how to disarm the system.”</p> <p>“Press and hold the Unlock button until the until the light on the keychain blinks.”</p>	<p>5. Watch and assist the customer.</p>

Bypassing Window or Door Sensors

This task guides you through teaching the end user how to arm the Concord system and make it ignore certain sensors. Use this task when you want to arm the system with a window or door open.

You can only bypass sensors using the touchpad or a telephone. The keychain touchpad cannot bypass sensors.

Touchpad: Bypass Window or Door Sensors



Read This	Do This
<p>“I’m going to show you how to bypass a door or window sensor on your Concord security system using a touchpad.”</p> <p>“With the system off, open the door or window that you want to bypass.”</p>	<p>1. Open a door or window (it must be one that has a working sensor installed.)</p>
<p>“Now, I’ll arm the system and bypass the open window.”</p>	<p>2. Show and tell the customer what you are doing as you enter the 2 or 3 + access code.</p>
<p>“Notice that the touchpad displays the number of the sensor that we left open.”</p> <p>“It also tells you the arming level.”</p> <p>“The speaker announces the arming level and which sensor we bypassed.”</p>	<p>3. Press BYPASS + access code + (sensor number).</p>
<p>“Go ahead and disarm the system now. Then it’s your turn to bypass a sensor.”</p>	<p>4. Assist the customer in disarming the system if necessary (press the 1 + access code).</p>
<p>“I’m going to talk you through bypassing a sensor.”</p> <p>“Arm the system to level 2 and press the BYPASS button. This will bypass any open sensors.”</p>	<p>5. Assist the customer as needed.</p>
<p>“Notice that the phone announced that a sensor is open.”</p> <p>“Do you have any questions or do you want to try it again?”</p>	

Telephone: Bypass Window or Door Sensors

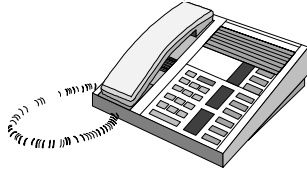

Read This	Do This
<p>“I’m going to show you how to bypass a door or window sensor on your Concord security system using a telephone.”</p> <p>“With the system off, open the door or window that you want to bypass.”</p>	<p>1. Open a door or window (it must be one that has a working sensor installed.)</p>
<p>“Now, I’ll arm the system.”</p>	<p>2. Show and tell and show the customer what you are doing as you enter # + 2 or 3 + the access code.</p>
<p>“Notice that the system sounds protest beeps telling you that a sensor is open.”</p>	<p>3. Show and tell the customer what you are doing as you press # + # to bypass the open sensor.</p>
<p>“Go ahead and disarm the system now. Then it’s your turn to bypass a sensor.”</p>	<p>4. Assist the customer in disarming the system if necessary (press the # + 1 + the access code.</p>
<p>“I’m going to talk you through bypassing a sensor.”</p> <p>“Arm the system to level 2, wait for the protest beeps, and press the pound sign (#) twice. This will bypass any open sensors.”</p>	<p>5. Assist the customer as needed.</p>
<p>“Notice that the phone announced that a sensor is open.”</p> <p>“Do you have any questions or do you want to try it again?”</p>	

Checking the System Status

This task guides you through teaching the end user how to status of the Concord system.

Touchpad: Checking the System Status



Read This	Do This
<p>“I’m going to show you how to check the status of your Concord system.”</p> <p>“There are two ways to check the system status: a short status check and a full status check.”</p> <p>“I’ll show you how to make a short status check first.”</p>	<p>1. Show and tell the customer as you press the STATUS button.</p>
<p>“Watch the touchpad display.”</p> <p>“If your system is OK, that is, everything is right, it will display, ‘System OK.’”</p> <p>“If there are any system troubles, it will tell display the problem area.”</p>	
<p>“It will also tell you if there were any recent alarms.”</p> <p>“The speaker will give one, two, or three short beeps. This tells you the arming level.”</p> <p>“Now, it’s your turn to do a full status check.”</p>	
<p>“Press the STATUS button twice. <i>(The second press should follow the first within 5 seconds.)</i></p>	<p>2. Watch and assist the customer as necessary.</p>
<p>“What problems did the system report?”</p>	



Full Status Check

Press the **STATUS** button twice. *(The second press should follow the first within 5 seconds.)*

The touchpad will display:

SYSTEM OK

or

Any system troubles and the temperature if the ESM is installed and turned on.

or

Any recent alarms

You will hear:



ONE, TWO, OR THREE SHORT BEEPS INDICATING THE CURRENT ARMING LEVEL.



Recent Alarm Check

Enter **7 + 6**.

The touchpad will display:

ALARM MEMORY OK

or

Any recent alarms

You will hear:



ONE, TWO, OR THREE SHORT BEEPS INDICATING THE CURRENT ARMING LEVEL OR "ALARM MEMORY IS OK."

Blank Page

Security
Automation
Fire Protection
Access Control



W I R E L E S S

Interactive Technologies, Inc.

2266 Second Street North
North Saint Paul, MN 55109-2900

T: 800/777-1415

F: 651/779-4890

WebSite: www.ititechnologies.com

©Interactive Technologies, Inc. August 1999

Specifications subject to change.

Some features are optional.

Document Number: 466-1619